

Control & Timing Relays

CS7 Industrial Control Relays	G2
<i>Technical Information & Dimensions (Online)</i>	G13
CS8 Industrial Control Relays	G17
<i>Technical Information & Dimensions (Online)</i>	G20
Next Gen RZ7 Electronic Timing Relays	G22.1
<i>Technical Information & Dimensions (Online)</i>	G22.8
RZ7-FS Electronic Timing Relays	G23
RZ7-FE Electronic Timing Relays	G32
<i>Technical Information & Dimensions (Online)</i>	G38

Relpol General Purpose Plug-In Relays

R2N/R4N Plug-in Power Relays	G43
R15 Plug-in Power Relays	G46
RUC Plug-in Power Relays	G50
RY2 Plug-in Power Relays	G52
PI84/PI85 Interface Relays	G54
PIR6W Interface Terminal Block Relays	G56
<i>Technical Information & Dimensions (Online)</i>	G58

GEFRAN Solid State Relays

Series GQ Panel Mount “Hockey Puck” Relays	G82
Series GTS 1-Pole DIN-Rail Mount Relays	G84
Series GTZ 3-Pole DIN-Rail Mount Relays	G86
Accessories	G87
<i>Technical Information & Dimensions (Online)</i>	
<i>Cross Reference SAS/SAR to Gefran</i>	G88
<i>Application Notes</i>	G89
<i>Technical Informaiton</i>	G94
<i>Wiring Diagrams & Dimensions</i>	G101



G Control, Timing & Solid State Relays

CS7 Industrial Control Relays

Reliable, general purpose relays for heavy duty applications

G
CS7 Control Relays

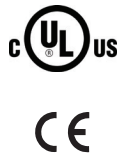

CS7 Industrial Control Relays share the same design as our modern CA7 contactor range. They are compact and designed for heavy duty industrial control applications where reliability and versatility are essential.

Introducing Three CS7 Models for any Control Application

The standard CS7 relay utilizes x-stamped contact technology that reliably switches typical control circuits up to 10A (AC-15). For master relay circuits requiring higher amp capacity, the CS7-M Master Relay is designed for control circuits up to 15A (AC-15).

For applications requiring low energy switching such as PLC's or other electronic circuits, the CS7-B relay with bifurcated contacts is designed for 20 million operations down to a signal level of 5V @ 3mA.

The bifurcated H-bridge design divides each movable gold contact into two sections at the tip of the spanner which provides a higher degree of reliability for low signal applications.

Auxiliary components provide a range of options

CS7 auxiliary components convert the basic four pole relay into a:

- 5, 6, 7, 8, 9, 10, 11 or 12 pole relay
- 4, 5, 6, 7 or 8 pole latched relay
- 4, 5, 6, 7 or 8 pole relay with two pneumatic time delay contacts
- Mechanically latched 4, 5, 6, 7 or 8 pole relay
- Also available are top mounted bifurcated auxiliary contacts which operate down to 5V @ 3mA.

Since the CS7 uses the same auxiliary components as our CA7 contactors, inventory is reduced and selection of components is simplified with this modular system.



Mechanically linked contacts for safety

CS7 control relays are perfect for fail-safe control circuits. An interlock contact design, which maintains minimum 0.3mm clearance, prevents the NC contact from reclosing if the NO contact is welded when in operation. This feature not only includes the base contact poles, but extends to the front and/or side mounted auxiliary contacts. This is a requirement in safety circuits and is backed by SUVA-PRO certification.

Maximum convenience and safety

CS7 relays are designed for fast and trouble free installation and maintenance. All components are modular and snap-on without the use of tools. The relays are DIN-rail mountable so they can be installed, moved or replaced quickly. All terminals are "captive" and are shipped in the open position, saving you an operation. The entire line is UL Listed, CSA Certified and CE marked and offers finger and back of hand protection to the strictest international standards.

Effortless installation

CS7 relays are DIN-rail mountable for instant installation and modification. Fittings are also included for base mounting. All terminals are clearly marked and ready for installation with either manual or power screwdrivers. A complete identification system is also available using self-adhesive labels, paper tags or plastic clip-on tags.

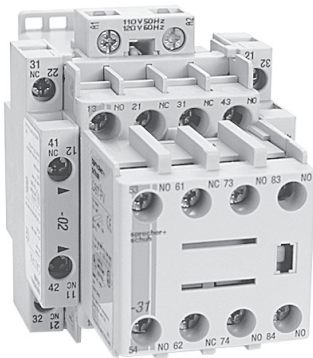

The base four pole CS7 relay can be expanded up to twelve poles with the addition of front and side mount auxiliaries

Series CS7 Standard Control Relays - 4 Pole ①④

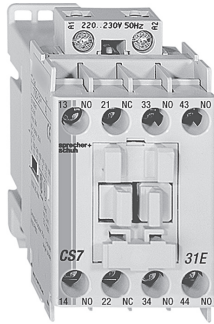
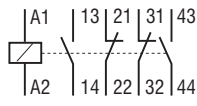
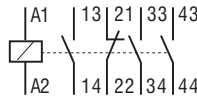
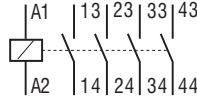
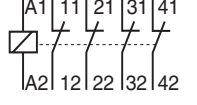
CS7 Relay	Contact Arrangement and Numbering	Contacts ①		AC Operation	Electronic DC ⑤
		NO	NC	Catalog Number	Catalog Number
 <p>CS7-31E</p>		2	2	CS7-22E-*	CS7E-22E-*
		3	1	CS7-31E-*	CS7E-31E-*
		4	0	CS7-40E-*	CS7E-40E-*
		0	4	CS7-04E-*	CS7E-04E-*

Contact Ratings (Per UL508/NEMA A600 & P600)

Standard	Circuit Voltage	Make (Amps/VA)	Break (Amps/VA)	Continuous Amps
A600	120AC	60A/7200VA	6A/720VA	10
	240AC	30A/7200VA	3A/720VA	
	480AC	15A/7200VA	1.5A/720VA	
	600AC	12A/7200VA	1.2A/720VA	
P600	125DC ②	1.1A/138VA	1.1A/138VA	5
	250DC ②	0.55A/138VA	0.55A/138VA	
	301-600DC ②	0.2A/138VA	0.2A/138VA	

Other UL Ratings

Maximum Voltage 600 volts AC or DC

General Purpose Amps

CS7 25 amps

Auxiliaries (@ 40°C) 10 amps

Auxiliaries (@ 60°C) 6 amps

AC Coil Codes ③

AC Coil Code	Voltage Range	
	50 Hz	60 Hz
24Z	24V	24V
120	110V	120V
220W	200-220V	208-240V
277	240V	277V
415	400-415V	~
480	440V	480V
600	550V	600V

DC Coil Codes ⑤

DC Coil Codes	Voltage
12E	12V
24E	24V
36E ⑥	36-48V
48E ⑥	48-72V
110E ⑥	110-125V
220E ⑥	220-250V

Ordering Instructions

Specify Catalog Number	
Replace (*) with Coil Code	See Coil Codes on this page

① Side mounted and/or top auxiliaries may be field installed to increase the number of available poles, limitations apply. Refer to page G14 for ordering and restriction details. Please note that side mount auxiliary terminal markings may conflict with base relay and/or top mount auxiliary terminal markings.

② DC rating for CS7 base control relay.

③ Other voltages available, see page G12.

④ Positively-Guided/Mechanically-Linked Contacts per IEC 947-5-1 Annex L on 4 main poles.

⑤ CS7E electronic coils are not interchangeable with non-electronic DC or AC coils.

⑥ Not applicable with Electronic Timer accessories (CRZ_7).

Series CS7-B Control Relays - 4 Pole, Bifurcated Contacts for Lower Level Signals ①④

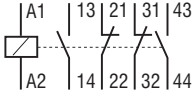
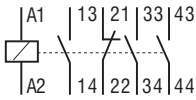
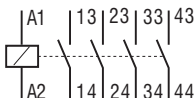
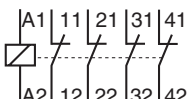
CS7-B Relay	Contact Arrangement and Numbering	Contacts ①		AC Operation	Electronic DC ⑤
		NO	NC	Catalog Number	Catalog Number
 <p>CS7-B22E</p>		2	2	CS7-B22E-*	CS7E-B22E-*
		3	1	CS7-B31E-*	CS7E-B31E-*
		4	0	CS7-B40E-*	CS7E-B40E-*
		0	4	CS7-B04E-*	CS7E-B04E-*

Contact Ratings (Per UL508/NEMA A600 & Q600)

Standard	Circuit Voltage	Make (Amps/VA)	Break (Amps/VA)	Continuous Amps
A600	120AC	60A/7200VA	6A/720VA	10
	240AC	30A/7200VA	3A/720VA	
	480AC	15A/7200VA	1.5A/720VA	
	600AC	12A/7200VA	1.2A/720VA	
Q600	125DC ②	0.55A/69VA	0.55A/69VA	2.5
	250DC ②	0.27A/69VA	0.27A/69VA	
	301-600DC ②	0.1A/69VA	0.1A/69VA	

CS7-B Bifurcated Control Relay

- Gold plated bifurcated contacts for low level switching application, min 5V, 3mA
- Maximum voltage 600V AC or DC
- General purpose amps - 10 amps
- Positively guided/mechanically-linked main contacts

Principle moving contact designs:



CS7-B
Bifurcated Contacts



CS7
Standard Contacts

AC Coil Codes ③

AC Coil Code	Voltage Range	
	50 Hz	60 Hz
120	110V	120V

DC Coil Codes ⑤

DC Coil Codes	Voltage
12E	12V
24E	24V
36E ⑥	36-48V
48E ⑥	48-72V
110E ⑥	110-125V
220E ⑥	220-250V

Ordering Instructions

Specify Catalog Number	
Replace (*) with Coil Code	See Coil Codes on this page

- ① Side mounted and/or top auxiliaries may be field installed to increase the number of available poles, limitations apply. Refer to page G14 for ordering and restriction details. Please note that side mount auxiliary terminal markings may conflict with base relay and/or top mount auxiliary terminal markings.
- ② DC rating for CS7-B base control relay.
- ③ Other AC voltages available, see page G12.
- ④ Positively-Guided/Mechanically-Linked Contacts per IEC 947-5-1 Annex L on 4 main poles.
- ⑤ CS7E electronic coils are not interchangeable with non-electronic DC or AC coils.
- ⑥ Not applicable with Electronic Timer accessories (CRZ_7).

Series CS7 Master Control Relays - 4 Pole ①④

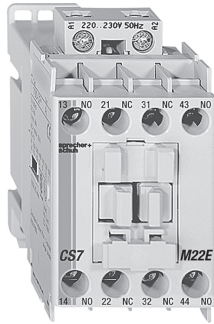
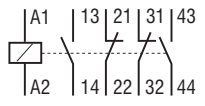
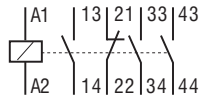
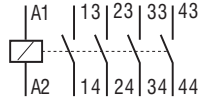
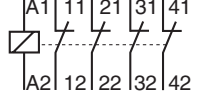
CS7-M Relay	Contact Arrangement and Numbering	Contacts ①		AC Operation	Electronic DC ⑤
		NO	NC	Catalog Number	Catalog Number
 <p>CS7-M22E</p>		2	2	CS7-M22E-*	CS7E-M22E-*
		3	1	CS7-M31E-*	CS7E-M31E-*
		4	0	CS7-M40E-*	CS7E-M40E-*
		0	4	CS7-M04E-*	CS7E-M04E-*

Contact Ratings (Per UL508/NEMA A600 & P600)

Standard	Circuit Voltage	Make (Amps/VA)	Break (Amps/VA)	Continuous Amps
A600	120AC	60A/7200VA	6A/720VA	20
	240AC	30A/7200VA	3A/720VA	
	480AC	15A/7200VA	1.5A/720VA	
	600AC	12A/7200VA	1.2A/720VA	
	125DC ②	1.1A/138VA	1.1A/138VA	
250DC ②	0.55A/138VA	0.55A/138VA		
301-600DC ②	0.2A/138VA	0.2A/138VA		

CS7-M Master Control Relays

- Excellent replacement for heavy duty NEMA master relay users.
- Maximum voltage 600V AC or DC
- General purpose rating 30 amps (2X A600 for CS7-M Base Relay)

Principle moving contact designs:



CS7-M
Contacts For
Master Control Relay



CS7
Standard Contacts

AC Coil Codes ③

AC Coil Code	Voltage Range	
	50 Hz	60 Hz
120	110V	120V

DC Coil Codes ⑤

DC Coil Codes	Voltage
12E	12V
24E	24V
36E ⑦	36-48V
48E ⑦	48-72V
110E ⑦	110-125V
220E ⑦	220-250V

Ordering Instructions

Specify Catalog Number	
Replace (*) with Coil Code	See Coil Codes on this page

- ① Side mounted and/or top auxiliaries may be field installed to increase the number of available poles, limitations apply. Refer to page G14 for ordering and restriction details. Please note that side mount auxiliary terminal markings may conflict with base relay and/or top mount auxiliary terminal markings.
- ② DC rating for CS7-M base control relay.
- ③ Other AC voltages available, see page G12.
- ④ Positively-Guided/Mechanically-Linked Contacts per IEC 947-5-1 Annex L on 4 main poles.
- ⑤ CS7E electronic coils are not interchangeable with non-electronic DC or AC coils.
- ⑦ Not applicable with Electronic Timer accessories (CRZ_7).

CS7 Complete Assemblies - 6 Pole, AC Control ①⑤

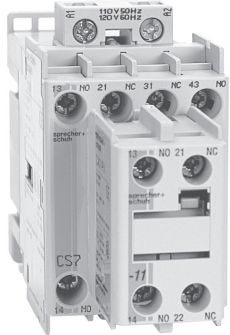
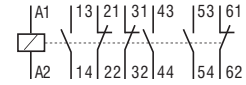
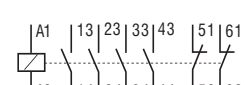
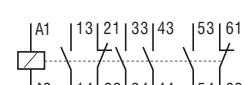
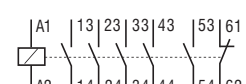
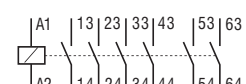
CS7 Relay	Contact Arrangement and Numbering	Contacts ①		AC Operation
		NO	NC	Catalog Number
 <p>CS7-33Y</p>		3	3	CS7-33Y-*
		4	2	CS7-42E-*
		4	2	CS7-42Y-*
		5	1	CS7-51E-*
		6	0	CS7-60E-*

G CS7 Control Relays

AC Coil Codes ④

AC Coil Code	Voltage Range	
	50 Hz	60 Hz
24Z	24V	24V
120	110V	120V
220W	200-220V	208-240V
277	240V	277V
415	400-415V	~
480	440V	480V
600	550V	600V

Contact Ratings (Per UL508/NEMA A600, P600 & Q600)

Standard	Circuit Voltage	Make (Amps/VA)	Break (Amps/VA)	Continuous Amps
A600	120AC	60A/7200VA	6A/720VA	10
	240AC	30A/7200VA	3A/720VA	
	480AC	15A/7200VA	1.5A/720VA	
	600AC	12A/7200VA	1.2A/720VA	
P600	125DC ②	1.1A/138VA	1.1A/138VA	5
	250DC ②	0.55A/138VA	0.55A/138VA	
	301-600DC ②	0.2A/138VA	0.2A/138VA	
Q600	125DC ③	0.55A/69VA	0.55A/69VA	2.5
	250DC ③	0.27A/69VA	0.27A/69VA	
	301-600DC ③	0.1A/69VA	0.1A/69VA	

Other UL Ratings

Maximum Voltage

600 volts AC or DC

General Purpose Amps

CS7 25 A

Aux. (@40°C) 10 A

Aux. (@60°C) 6 A

Ordering Instructions

Specify Catalog Number	
Replace (*) with Coil Code	See Coil Codes on this page

① Side mounted and/or top auxiliaries may be field installed to increase the number of available poles, limitations apply. Refer to page G14 for ordering and restriction details. Please note that side mount auxiliary terminal markings may conflict with base relay and/or top mount auxiliary terminal markings.

② DC rating for CS7 base control relay.

③ DC rating for CS7 auxiliary blocks.

④ Other voltages available, see page G12.

⑤ Positively-Guided/Mechanically-Linked Contacts per IEC 947-5-1 Annex L on 4 main poles and auxiliaries.

CS7 Complete Assemblies - 8 Pole, AC Control ①⑤

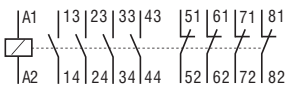
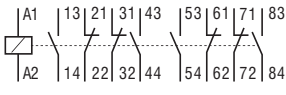
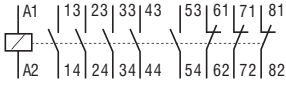
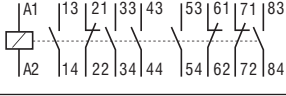
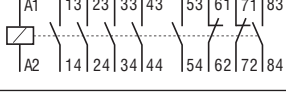
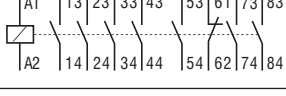
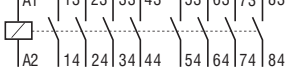
CS7 Relay	Contact Arrangement and Numbering	Contacts ①		AC Operation
		NO	NC	Catalog Number
 <p>CS7-44E</p>		4	4	CS7-44E-*
		4	4	CS7-44Y-*
		5	3	CS7-53E-*
		5	3	CS7-53Y-*
		6	2	CS7-62E-*
		7	1	CS7-71E-*
		8	0	CS7-80E-*

AC Coil Codes ④

AC Coil Code	Voltage Range	
	50 Hz	60 Hz
24Z	24V	24V
120	110V	120V
220W	200-220V	208-240V
277	240V	277V
415	400-415V	~
480	440V	480V
600	550V	600V

Contact Ratings (Per UL508/NEMA A600, P600 & Q600)

Standard	Circuit Voltage	Make (Amps/VA)	Break (Amps/VA)	Continuous Amps
A600	120AC	60A/7200VA	6A/720VA	10
	240AC	30A/7200VA	3A/720VA	
	480AC	15A/7200VA	1.5A/720VA	
	600AC	12A/7200VA	1.2A/720VA	
P600	125DC ②	1.1A/138VA	1.1A/138VA	5
	250DC ②	0.55A/138VA	0.55A/138VA	
	301-600DC ②	0.2A/138VA	0.2A/138VA	
Q600	125DC ③	0.55A/69VA	0.55A/69VA	2.5
	250DC ③	0.27A/69VA	0.27A/69VA	
	301-600DC ③	0.1A/69VA	0.1A/69VA	

Other UL Ratings

Maximum Voltage

600 volts AC or DC

General Purpose Amps

CS7 25 A

Aux. (@40°C) 10 A

Aux. (@60°C) 6 A

Ordering Instructions

Specify Catalog Number	
Replace (*) with Coil Code	See Coil Codes on this page

① Side mounted and/or top auxiliaries may be field installed to increase the number of available poles, limitations apply. Refer to page G14 for ordering and restriction details. Please note that side mount auxiliary terminal markings may conflict with base relay and/or top mount auxiliary terminal markings.

② DC rating for CS7 base control relay.

③ DC rating for CS7 auxiliary blocks.

④ Other voltages available, see page G12.

⑤ Positively-Guided/Mechanically-Linked Contacts per IEC 947-5-1 Annex L on 4 main poles and auxiliaries.

Side Mount Auxiliary Contact Blocks (1 & 2 Pole) ①②

Contact Block	Description	NO	NC	Contact Arrangement	For use with...	Standard Contacts Catalog Number
 <p>1-pole (typical)</p> <p>2-pole (typical)</p>	Auxiliary Contact Blocks for Side Mounting ①② <ul style="list-style-type: none"> • 1 and 2-pole • Two way numbering for right or left mounting on the contactor • Snap-on design - mounts without tools • Electronic compatible contacts 17V, 10mA • Late break / early make (L) available • Mirror contact performance to control relay poles 	0	1		CS7 all	CA7-PA-01
		1	0		CS7 all	CA7-PA-10
		0	2		CS7 all	CA7-PA-02
		1	1		CS7 all	CA7-PA-11
		2	0		CS7 all	CA7-PA-20
		1L	1L		CS7 all	CA7-PA-L11

Top Mount Auxiliary Contact Blocks (2 & 4 Pole) ②

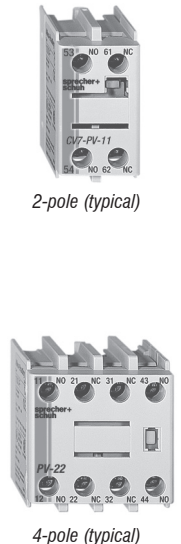
Contact Block	Description	NO	NC	Contact Arrangement	For use with...	Standard Contacts Catalog Number	Bifurcated Contacts Catalog Number
 <p>2-pole (typical)</p> <p>4-pole (typical)</p>	Auxiliary Contact Blocks for Top Mounting ② <ul style="list-style-type: none"> • 2 and 4 pole • Snap-on design - mounts without tools • Electronic compatible standard contacts down to 17V, 5mA, bifurcated version 5V, 3mA • Mechanically linked between N.O. and N.C. poles and to the control relay poles (excluding L types). • Several terminal numbering choices even for models with equal function • Late break / early make (L) available 	0	2		CS7 all	CS7-PV-02	CS7-PVB-02
		1	1		CS7 all	CS7-PV-11	CS7-PVB-11
		2	0		CS7 all	CS7-PV-20	CS7-PVB-20
		2	2		CS7 all	CS7-PV-22	CS7-PVB-22
		3	1		CS7 all	CS7-PV-31	CS7-PVB-31
		1	3		CS7 all	CS7-PV-13	CS7-PVB-13
		4	0		CS7 all	CS7-PV-40	CS7-PVB-40
		0	4		CS7 all	CS7-PV-04	CS7-PVB-04
		1+1L	1+1L		CS7 all	CS7-PV-L22	Not Available

① Side mounted auxiliaries may be field installed to increase the number of available poles. Please note that terminal markings may conflict with base relay and/or top mount auxiliary terminal markings.

② See page G14 for maximum number of auxiliaries to be mounted.

Control Modules

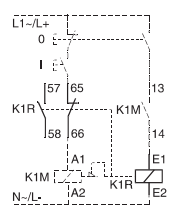
Module	Description	For use with...	Connection Diagrams	Catalog Number
	<p>Mechanical Latch Following relay latching, the relay coil is immediately de-energized by the NC auxiliary contact (65-66).</p> <ul style="list-style-type: none"> • Electrical or manual release • 1 NO + 1 NC auxiliary switch • Suitable for all CS7 relays 	CS7 all		<p>CV7-11-* Replace * with coil code below (See Application Note)</p>

CV7 Mechanical Latch Coil Codes ①②③④⑤

Coil Code	Application Range			Latch & Contactor Coil Rating
	50 Hz	60 Hz	VDC	
24Z	24 VAC	24 VAC	12 VDC	24V 50/60 Hz
48Z	48 VAC	48 VAC	24 VDC	48V 50/60 Hz
110	100 VAC	110 VAC	48 or 60VDC	110V50/110V60
120	110 VAC	120 VAC	~	110V50/120V60
220W	~	208...240 VAC	~	208...240V60
230Z	230 VAC	230 VAC	110 VDC	230V 50/60 Hz
240Z	240 VAC	240 VAC	125 VDC	240V 50/60 Hz
277	240 VAC	277 VAC	~	240V50/277V60
380	380...400 VAC	440 VAC	~	380...400V50/440V60
400Z	400 VAC	400 VAC	220 VDC	400V 50/60 Hz
415	400...415 VAC	~	~	400...415 V50 Hz
480	440 VAC	480 VAC	~	440V50/480V60
600	550 VAC	600 VAC	~	550V50/600V60







APPLICATION NOTE:

The CV7 Mechanical Latch for CS7 Control Relay may be used for both AC and DC applications; however when using DC control circuit the user must apply the following rules for coil selection of the control relay and latch combination:

- The CS7E control relay uses an electronic DC coil and the CV7 latch coil code should be chosen from the table on the left. (i.e.: 24V DC control circuit select CS7E with code 24E and CV7 latch uses a 48Z AC coil code).



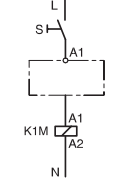
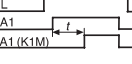

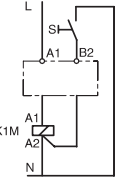
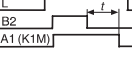
- ① Other voltages available. Contact your Sprecher + Schuh representative.
- ② CV7 must be wired for momentary impulse operation only.
- ③ Command duration 0.03...15 seconds.
- ④ Use 600V AC when 575 V is required.
- ⑤ Coil operating limits on CV7-11 match those of the relay it is being used with.

Control Modules

Module	Description	For use with...	Connection Diagrams	Function	Catalog Number
	Pneumatic Timing Module – The contacts in the Pneumatic Timing Element switch after the delay time. The contacts on the relay continue to operate without delay. <ul style="list-style-type: none"> Continuous adjustment range 	CS7 all ❶		ON-Delay .3...30s 1.8...180s	CZE7-30 CZE7-180
				OFF-Delay 0.3...30s 1.8...180s	CZA7-30 CZA7-180
	Electronic Timing Module – ❶ ON-Delay The relay is energized at the end of the delay time.	CS7 with 110...240V, 50/60Hz or 110...250V DC		110...240V 50/60Hz 110...250V DC 0.1...3s 1...30s 10...180s	CRZE7-3-110/240 CRZE7-30-110/240 CRZE7-180-110/240
		CS7 with 24...48V DC		24...48V DC 0.1...3s 1...30s 10...180s	CRZE7-3-24/48VDC CRZE7-30-24/48VDC CRZE7-180-24/48VDC
	Electronic Timing Module – ❶ OFF-Delay After interruption of the control signal, the relay is de-energized at the end of the delay time.	CS7 with 24V, 50/60Hz		110...240V 50/60Hz 0.3...3s 1...30s 10...180s	CRZA7-3-110/240 CRZA7-30-110/240 CRZA7-180-110/240
		CS7 with 110...240V, 50/60Hz		24V AC 50/60Hz 0.3...3s 1...30s 10...180s	CRZA7-3-24VAC CRZA7-30-24VAC CRZA7-180-24VAC

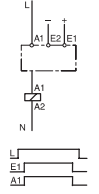
❶ Cannot be used with side-mounted auxiliary contacts on CS7 relays with DC coils.

Control Modules (continued)

Module	Description	For use with...	Connection Diagrams	Function		Catalog Number
				Input	Output	
	<p>Electronic Interface – Interface between the DC control signal from a PLC and the AC operating mechanism of the relay.</p> <ul style="list-style-type: none"> Requires no additional surge suppression for the coils Switching capacity 200VA Suitable for all CS7 relays 	CS7 all (with AC control)		24V DC 18...30V DC 48V DC	110... 240V AC	<p>CRI7E-24 CRI7E-12 CRI7E-48 <i>Indicates special order</i></p>
	<p>Surge Suppressors - Limits coil switching transients.</p> <ul style="list-style-type: none"> Plug-in, coil mounted Suitable for all CS7 contactors 	CS7 all (with AC control)		<p>RC Module - AC Control (50/60Hz) 24...48V 110...280V 380...480V</p>		<p>CRC7-48 CRC7-280 CRC7-480</p>
		CS7C (with conventional DC control)		<p>Diode Module - DC Control 12-250VDC</p>		<p>CRD7-250 ①</p>
		CS7 all (with AC control) CS7C (with conventional DC control)		<p>Varistor Module - AC/DC Control 12...55VAC/ 12...77VDC 56...136VAC/ 78...180VDC 137...277VAC/ 181...350VDC 278...575VAC</p>		<p>CRV7-55 ① CRV7-136 ① CRV7-277 ① CRV7-575 ①</p>

Assembly Components

Component	Description	For Use With...	Pkg. Qty.	Catalog Number
	<p>Spade Connectors - Dual stab for coil terminals (0.250 inch)</p>	All CS7	20	CA7-SC2

Other Common Accessories

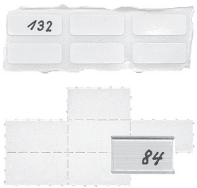
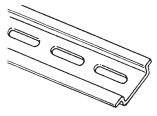
	<p>Protective Covers - See page A54</p>	 <p>Marking Systems - like Label Sheets, Marker Tags and Carrier Tags See page A54</p>	 <p>DIN-rail – See page N30</p>
-------------------------------------------------------------------------------------	------------------------------------------------	----------------------------------------------------------------------------------------------------------------------------------------------------------------------------------	-----------------------------------------------------------------------------------------------------------------------------

① Electronic DC Control Relays (CS7E) include internal surge protection and do not require additional external surge protection.

Renewal Coils - AC ❶

AC Control Voltages			AC Coil Codes ❶	Electronic AC Coils
50 Hz	60 Hz	50/60 Hz		Cat. No.
				CA7-
~	~	24V	24Z	TA855
110V	120V	~	120	TA473
115V	127V	~	127	TA424
~	208V...240V	~	220W	TA296
~	~	230V	230Z	TA851
240V	277V	~	277	TA480
400V...415V	~	~	415	TA457
440V	480V	~	480	TA475
550V	600V	~	600	TA476

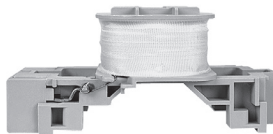

CS7 AC coil (typical)

Renewal Coils - Electronic DC ❷

DC Control Voltages	DC Coil Codes ❶	Electronic DC Coils
		Cat. No.
		CA7-
12V	12E	TC708E
24V	24E	TC714E
36-48V	36E	TC719E
48-72V	48E	TC724E
110-125V	110E	TC733E
220-250V	220E	TC747E

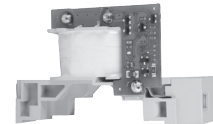

12V & 24V Electronic DC coil ❷

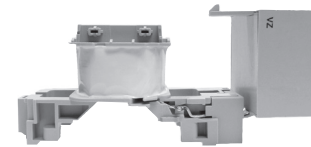

36V...220V Electronic DC coil with Back Pack ❷

❶ Coil Codes in bold letters indicate coils that are standard stocked items.

❷ Electronic DC Coils are not interchangeable with non-electronic DC or AC coils.

Technical Information

		Standard Control Relay CS7	Front Mounted Standard Auxiliary Contacts	Bifurcated Control Relay CS7-B	Front Mounted Bifurcated Auxiliary Contacts	Master Relay CS7-M	Side Mounted Contacts
Electrical Contact Ratings - NEMA		A600, P600	A600, Q600			2x A600, P600	A600, Q600
Min. Contact Rating		17V, 10 mA	17V, 5 mA	8V, 5 mA	5V, 3 mA		17V, 10 mA
Contact Ratings - IEC AC-15 (solenoids, contactors) rated voltage IEC 60947-5-1	24V	10 A	6 A	3 A	3 A	15 A	6 A
	48V	10 A	6 A	3 A	3 A	15 A	6 A
	120V	10 A	6 A	3 A	3 A	15 A	6 A
	240V	10 A	5 A	3 A	3 A	15 A	5 A
	400V	6 A	3 A	2 A	2 A	7.5 A	3 A
	480V/500V	2.5 A	1.6 A	1.2 A	1.2 A	5 A	1.6 A
	600V	1 A	1 A	0.7 A	0.7 A	2 A	1 A
	690V	1 A	1 A	0.7 A	0.7 A	2 A	1 A
AC-12 (Control of resistive loads) IEC 60947-5-1	40 °C	I_{th}	20 A	10 A	10 A	10 A	20 A
		230V	8 kW				
		400V	14 kW				
		690V	24 kW				
	60 °C	I_{th}	20 A	6 A	6 A	6 A	20 A
		230V	8 kW				
	400V	14 kW					
	690V	24 kW					
DC-12 Switching DC Loads $t_{cr} < 1$ ms, Resistive Loads IEC 60947-5-1	24V	15 A	10 A	6 A	6 A	20 A	6 A
	48V	10 A	9 A	3.2 A	3.2 A	20 A	3.2 A
	110V	6 A	3.5 A	1.0 A	1.0 A	8 A	1.0 A
	220V	1.0 A	0.7 A	0.5 A	0.5 A	1.5 A	0.5 A
	440V	0.4 A	0.2 A	0.2 A	0.2 A	0.4 A	0.2 A
DC-13 IEC 60947-5-1, Solenoids and contactors	24V	5 A	5 A	2.5 A	2.5 A	5 A	5 A
	48V	3 A	3 A	1.5 A	1.5 A	3 A	2.5 A
	110V	1.2 A	1.2 A	0.6 A	0.6 A	1.2 A	0.68 A
	220V	0.6 A	0.6 A	0.3 A	0.3 A	0.6 A	0.32 A
	440V	0.3 A	0.15 A	0.15 A	0.15 A	0.3 A	0.15 A

CS7 Relays Front Mount Auxiliaries & Pneumatic Timer Contacts

Mechanically Linked Contacts

Location of welded NO contacts	State of NC contacts if NO contact welds			
	Main	Front mount auxiliary	Left side auxiliary	Right side auxiliary
Main	Open	Open ①	Open ②	Open ③
Front auxiliary	Open	Open ①	Open ②	Open ③
Left side aux.	Open	Open ①	Open ②	Open ③
Right side aux.	Open	Open ①	Open ②	Open ③





DC Switching Ratings for CS7 Main Poles in Series (Resistive Load at 60 °C)

	1 pole	2 poles	3 poles
24/48 V	25/20 A	25 A	25 A
125 V	6 A	25 A	25 A
220 V	1.5 A	8 A	25 A
440 V	0.4 A	1 A	3 A

Standards Compliance

UL 508
 CSA C22.2 NO. 14
 EN/IEC 60947-1, -5-1
 Meets the material restrictions for European Directive 2002/95/EC - EU-RoHS.

Mechanical

Mechanical Life	[Mil]	15	5
Electrical Life			
AC-15 (240V, 3A) AC Operations	[Mil]	1.5	1.5
Shipping Weight			
AC - CS7	[kg]	0.39	
	[lbs]	0.86	
DC - CS7E	[kg]	0.41	
	[lbs]	0.90	
Terminal Cross-Sections			
Terminal Type			
Terminal Size per IEC 947-1		2 x A4	2 x A4
 Flexible with Wire End Ferrule	1 Cond.	[mm²]	1...4
	2 Cond.	[mm²]	1...4
 Solid/Stranded	1 Cond.	[mm²]	1.5...6
	2 Cond.	[mm²]	1.5...6
Max. Wire Size per UL/CSA	[AWG]	16...10	18...14
Tightening Torque	[Nm]	1.5...2.0	1...1.5
	[lb-in]	13.3...17.7	8.9...13.3

Certifications

cULus Listed (File No. E33916, Guide NKCR/NKCR7)

CE Marked

- ① If the accessory is a Pneumatic Timer or latch, there is no positive guidance; the accessory contacts are independent.
- ② Defined in IEC 947-5-1 annex L. Mechanically linked is a relationship between contacts of opposite types (i.e., NO and NC).
- ③ Side mounted auxiliary contacts provide "mirror contact" performance with main poles only.

Technical Information

Rated Insulation Voltage U_i		Corrosion Resistance	
IEC	690V	humid-alternating climate, cyclic, per IEC 68-2-30 and DIN 50 016, 56 cycles	
UL; CSA	600V		
Rated Impulse Strength U_{imp}		Altitude	
	6 kV	2000m above main sea level, per IEC 947-4	
High Test Voltage		Type of Protection	
1 minute (per IEC 947-4)	2500V	IP 2X (IEC 60529 and DIN 40050) in connected state	
Rated Voltage U_e		Finger Protection	
AC	115, 230, 400, 500, 690V	safe from touch by fingers and back of hand per VDE 0106, Part 100	
DC	24, 48, 110, 220, 440V		
Rated Frequency		Shock Protection	
	50/60 Hz, DC	IEC 68-2: Half Sinusoidal shock 11ms 30G (in 3 directions)	
Ambient Temperature		Vibration Resistance	
Storage	-55...+80°C (-67...176°F)	IEC 68-2: static >2G in normal position no malfunction <5G	
Operation at nominal current	-25...+60°C (-13...140°F)		
Conditioned 15% current reduction after AC-1 at > 60°C	-25...+70°C (-13...158°F)		

Coil Data - AC Control Circuit

Operating Voltage Range	Pickup	[x U_s]	0.85...1.1
	Dropout	[x U_s]	0.3...0.6
Coil Consumption	Inrush	[VA]	75
	Seal	[VA/W]	9.5/2.7
Operating Times	Pickup Time	[ms]	15...30
	Dropout Time	[ms]	10...60

Latch Attachment Release, CV7-11

Coil Consumption	AC	[VA/W]	45 / 40
	DC	[W]	25

Contact Signal Duration	[min/max]	0.03...15s
--------------------------------	-----------	------------

Timing Attachment, CRZE7, CRZA7

Reset Time	at min. time setting	[ms]	10
	at max. time setting	[ms]	70
	Repeat Accuracy		± 10%

Coil Data - Electronic DC

Voltage Range			Coil Consumption & Operating Times ☉				
Voltage Code	Nominal Voltage US [V DC]	Ratings [x U_s]	Average/Peak Pickup [W]	Hold-in [W]	Dropout Voltage [x U_s]	Pickup [ms]	Dropout [ms]
12E	12	0.7...1.25	10/17	1.7	0.3...0.4	20...50	20...50
24E	24	0.7...1.25	10/17	1.7			
36E	36...48	0.7...1.25	10/17	1.7...1.9			
48E	48...72	0.8...1.25	10/17	1.7...1.9	0.3...0.4	20...50	23...33
110E	110...125	0.7...1.12☉	12/19	2.0...2.1			
220E	220...250	0.8...1.1	14/22	2.7...3.0			

Control Relays Maximum Auxiliary Contacts

CS7 (AC and DC electronic coils, vertical mounting, 60° C)	CS7(E)-40E	CS7(E)-31E	CS7(E)-22E	CS7(E)-04E
Maximum N.O. Side Auxiliaries	2	2	4	2
Maximum N.C. Side Auxiliaries	4	4 ①	4 ①	2
Maximum N.O. Front Auxiliaries	4	4	4	4
Maximum N.C. Front Auxiliaries	4	4 ②	2	0
Maximum N.O. Front + Side Auxiliaries	6	6	8	6
Maximum N.C. Front + Side Auxiliaries	7	5	5	2
Maximum N.O. + N.C. Front + Side Auxiliaries	8	8	8	6

- ① With no front auxiliary contacts installed. Otherwise 3 N.C. maximum.
- ② With no side mount auxiliary contacts installed. Otherwise 3 N.C. maximum.
- ③ The hold-in demand of the CS7E is very low but the pick-up demand is approximately 1 ampere at 24 VDC. When sizing (dimensioning) a power supply for applications involving parallel switched contactors then multiply the peak demand by the number of contactors to be simultaneously switched and add to the hold-in demand of all other control circuit burdens, including other contactors, pilot devices, solenoids, etc.
- ④ At 110VDC, coil code 110E has an operating range of 0.7...1.25 x U_s

Utilization Category Table from EN 947-5-1

Verification of Making and Breaking Capacities of Switching Elements Under Normal Conditions
Corresponding to the Utilization Categories ❶

Utilization Category	Normal Condition of Use								
	Make ❷			Break ❷			Number & Rate of Making & Breaking Operations		
	I/I _e	U/U _e	COS Ψ	I/I _e	U/U _e	COS Ψ	No. of operating cycles ❸	Operating cycles per minute	ON time(s) ❹
AC-12 ❸	1	1	0.9	1	1	0.9	6050	6	0.05
AC-13 ❸	2	1	0.65	1	1	0.65	6050	6	0.05
AC-14 ❸	6	1	0.3	1	1	0.3	6050	6	0.05
AC-15 ❸	10	1	0.3	1	1	0.3	6050	6	0.05
DC			T _{0.95}			T _{0.95}			
DC-12	1	1	1ms	1	1	1ms	6050	6	0.05 ❸
DC-13	1	1	6 x P ❹	1	1	6 x P ❹	6050	6	0.05 ❸
DC-14 ❸	10	1	15ms	1	1	15ms	6050	6	0.05 ❸

I_e Rated operational current
P=U_eI_e steady-state power consumption (W)

U_e Rated operational voltage. Current to be made or broken.

T_{0.95} Time to reach 95% of the steady-state current (ms) UVoltage before make

NEMA Ratings and Test Values for AC (50 and 60Hz) and DC Control Circuits Contacts

Designation ❶	Utilization Category	Therm. Continuous Test Current (A)	Maximum Current								VA	
			120V		240V		480V		600V			
AC			Make	Break	Make	Break	Make	Break	Make	Break	Make	Break
A150	AC-15	10	60	6.00	~	~	~	~	~	~	7200	720
A300	AC-15	10	60	6.00	30	3.00	~	~	~	~	7200	720
A600	AC-15	10	60	6.00	30	3.00	15	1.50	12	1.20	7200	720
B150	AC-15	5	30	3.00	~	~	~	~	~	~	3600	360
B300	AC-15	5	30	3.00	15	1.50	~	~	~	~	3600	360
B600	AC-15	5	30	3.00	15	1.50	7.5	0.75	6	0.60	3600	360
C150	AC-15	2.5	15	1.50	~	~	~	~	~	~	1800	180
C300	AC-15	2.5	15	1.50	7.5	0.75	~	~	~	~	1800	180
C600	AC-15	2.5	15	1.50	7.5	0.75	3.75	0.375	3	0.30	1800	180
D150	AC-14	1.0	3.60	0.60	~	~	~	~	~	~	432	72
D300	AC-14	1.0	3.60	0.60	1.8	0.30	~	~	~	~	432	72
E150	AC-14	0.5	1.80	0.30	~	~	~	~	~	~	216	36
2 x A300	AC-15	20	120	12	60	6.00	~	~	~	~	14400	1440
2 x A600	AC-15	20	120	12	60	6.00	30	3.00	24	2.40	14400	1440
DC			5...28V	125V	250V	301...600V	Make or Break at 300V or less [VA]					
N150	DC-13	10	10	2.2	~	~	275					
N300	DC-13	10	10	2.2	1.1	~	275					
N600	DC-13	10	10	2.2	1.1	0.40	275					
P150	DC-13	5.0	5.0	1.1	~	~	138					
P300	DC-13	5.0	5.0	1.1	0.55	~	138					
P600	DC-13	5.0	5.0	1.1	0.55	0.20	138					
Q300	DC-13	2.5	2.5	0.55	0.27	0.11	69					
Q600	DC-13	2.5	2.5	0.55	0.27	0.11	69					
2 x P600	DC-13	10	102.2	2.2	1.1	0.40	275					

❶ See sub-clause 8.3.3.5.2

❷ For tolerances on test quantities, see sub-clause 8.3.2.2

❸ The first 50 operating cycles shall be run at U/U_e=1.1 with the loads set at U_e

❹ The value "6 x P" results from an empirical relationship which is found to represent most DC magnetic loads to an upper limit of P = 50W, i.e. 6 x P = 300ms.

❺ The ON time shall be at least equal to T_{0.95}

❻ Where the break current differs from the make current value, the ON time refers to the make current value after which the current is reduced to break current value for a suitable period e.g., 0.05 s.

❼ This is the NEMA Contact Rating Designation, where the letter stands for the conventional thermal current and identifies AC or DC: e.g., B = 5A AC. The number that follows is the rated insulation voltage.

Series CS7 Industrial Control Relays (AC and Electronic DC)

Dimensions are in millimeters (inches). Dimensions not intended for manufacturing purposes.

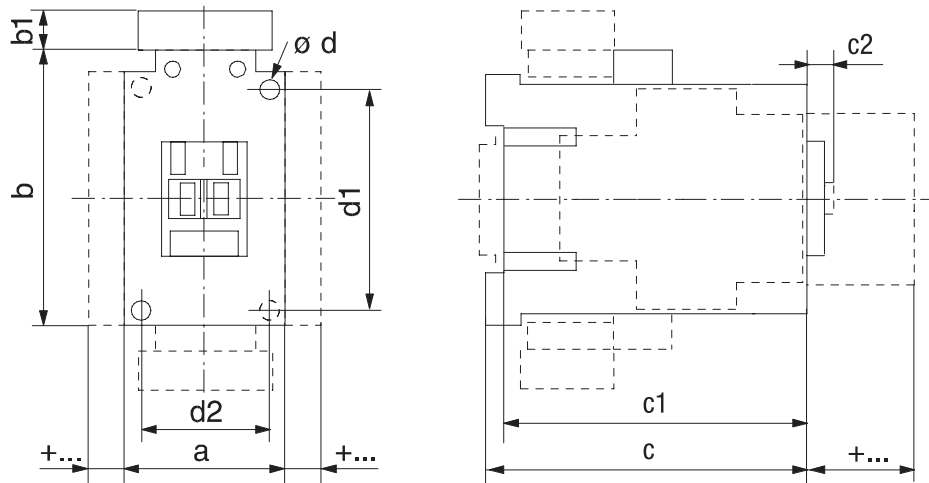

Catalog Number	Coil Code	a	b	b1	c	c1	c2	⌀d	d1	d2
CS7 (AC)	All	45 (1-25/32)	81 (3-3/16)	~	80.5 (3-11/64)	75.5 (3-3/32)	6 (1/4)	① 4.5 (3/16)	60 (2-23/64)	35 (1-25/64)
CS7 (Electronic DC)	12E...24E	45 (1-25/32)	81 (3-3/16)	~	80.5 (3-11/64)	75.5 (2-31/32)	6 (15/64)	① 4.5 (3/16)	60 (2-23/64)	35 (1-3/8)
	36E...220E	45 (1-25/32)	81 (3-3/16)	24 (15/16)	80.5 (3-11/64)	75.5 (2-31/32)	6 (15/64)	① 4.5 (3/16)	60 (2-23/64)	35 (1-3/8)

Relays & Accessories (+...)

Relays with...		Dim. [mm]	Dim. [inches]
auxiliary contact block for front mounting	2-, or 4-pole	c/c1 + 39	c/c1 + 1-37/64
auxiliary contact block for side mounting	1-, or 2-pole	a + 9	a + 23/64
pneumatic timing module		c/c1 + 58	c/c1 + 2-23/64
electronic timing module	on coil terminal side	b + 24	b + 15/16
mechanical latch		c/c1 + 61	c/c1 + 2-31/64
interface module	on coil terminal side	b + 9	b + 23/64
surge suppressor	on coil terminal side	b + 3	b + 1/8
	label sheet	+ 0	+ 0
Labeling with...	marking tag sheet with clear cover	+ 0	+ 0
	marking tag adapter for V7 Terminals	+ 5.5	+ 7/32

Mounting Position

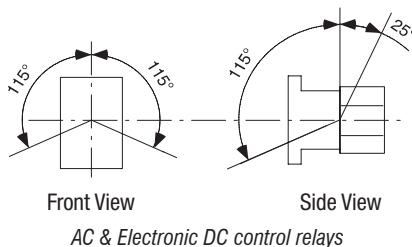

① 2 mounting holes.

CS8 Industrial Control Relays

The miniature relay system with big advantages



CS8 front mount auxiliaries are positive guidance

Despite increasing complexity, control systems and installations must become increasingly compact. And the CS8 Miniature Relay System packs maximum performance into minimum space.

Small but rugged

Sprecher + Schuh has subjected this relay series to monitored endurance tests that demonstrate their ruggedness. Under normal duty, CS8 contacts have an electrical life of 700,000 operations, while the AC magnet system has a mechanical life of 15,000,000 operations.

The coil is designed for absolute undervoltage reliability. Undervoltages that do not cause the contactor to close can be withstood indefinitely without damage.

The body of the device is sturdy as well. The front housing, containing the phase partitions and screwdriver guides, is manufactured in one piece. Front and rear housing are then joint fitted together.

Superior Contact Reliability

The standard CS8 base relay and auxiliary contacts are bifurcated H-bridge design which divides each movable contact into two sections at the tip of the spanner which provides a higher degree of reliability for low signal applications. Perfect fit for PLC and other electronic circuits operate at signals as low as 15V @ 2mA.

Mechanically linked contacts for safety

The CS8 control relays are the perfect choice for fail-safe control circuits to meet mechanically linked performance per IEC 60947-4-1. Mechanically linked is an interlock contact design that maintains minimum 0.5mm clearance which prevents the NC contact from reclosing if the NO contact is welded when in operation. This feature applies to CS8 base relays with AC & DC coils; base relays and add-on auxiliaries for DC coils only.



Accessories require no additional panel space

The entire CS8 system is logically engineered. Auxiliary contact blocks are modular and snap-on without increasing the CS8's original width of 45mm. Also, due to its sideways switching movement, the basic relay has the same low profile whether an AC or DC operating magnet is used. This permits the use of enclosures with shallow mounting depths. Once the CS8 is installed, all auxiliary contact blocks can be snapped on or removed without changing any existing wiring.

Auxiliary components provide flexibility

CS8 auxiliary components allow you to convert the basic four pole relay up to an 8 pole relay.

Effortless installation

CS8 relays are DIN-rail mountable for instant installation and modification. Fittings are also included for base mounting. All terminals are clearly marked and shipped in the open position for installation with either manual or power screwdrivers. Using self-adhesive labels, or plastic clip-on tags.

The entire line is cULus Listed and CE Certified and offers finger and back of hand protection to the strictest international standards.

CS8 Complete Assemblies - 4 Pole

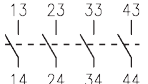
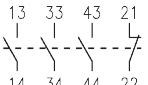
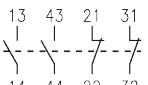
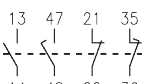
CS8 Relay	Contact Arrangement and Numbering	Contacts		AC Operation	DC Operation
		NO	NC	Catalog Number	Catalog Number
		4	0	CS8-40E-*	CS8C-40E-*
		3	1	CS8-31Z-*	CS8C-31Z-*
		2	2	CS8-22Z-*	CS8C-22Z-*
		1+ 1EM	1+ 1LB	CS8-L22Z-*	CS8C-L22Z-*

G CS8 Control Relays

Contact Ratings (Per UL508/NEMA B600 & Q600) Ⓢ

Standard	Circuit Voltage	Make (Amps/VA)	Break (Amps/VA)	Continuous Amps
B600	120AC	30A/3600VA	3.0A/360VA	10
	240AC	15A/3600VA	1.5A/360VA	
	480AC	7.5A/3600VA	0.75A/360VA	
	600AC	6A/3600VA	0.60A/360VA	
Q600	125DC	0.55A/69VA	0.55A/69VA	2.5
	250DC	0.27A/69VA	0.27A/69VA	
	301-600DC	0.1A/69VA	0.1A/69VA	

Mechanical Link

- Base relay meets IEC 60947-5-1. See page G20 for additional information.

AC Coil Codes ①

AC Coil Code	Voltage Range	
	50 Hz	60 Hz
12	12V	12V
24Z	24V	24V
48Z	48V	48V
120	110V	120V
208	200V-220V	208V-220V
240	240V	240V
380 ④	Use Coil Code 400	
400 ④	400V	400V
480	440V	480V
575 ⑤	Use Coil Code 600	
600 ⑤	525V	600V

DC Coil Codes ①

DC Coil Code	Voltage
12D	12V
24D	24V ②
110D	110V
125D	125V
220D	220V

Ordering Instructions

Specify Catalog Number	
Replace (□) with Coil Code	See Coil Codes on this page

- ① The coil codes shown are for the most commonly stocked items. Contact your Sprecher + Schuh representative to determine if other voltages are on-hand or can be specially ordered in quantity.
- ② Integrated diode surge suppressor coils available. Order coil code **24DD**. For example CS8C-22Z-**24D** becomes CS8C-22Z-**24DD**.
- ③ Contacts are bifurcated (H-bridge) with a minimum current rating of 2mA @ 15V.
- ④ The European Community has agreed that 400V is the nominal voltage in lieu of 380V. Use this code when 380V is required.
- ⑤ Use this code for 575V applications.

Auxiliary Contact Blocks (2 & 4 Pole) ①③

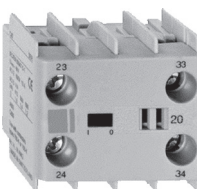
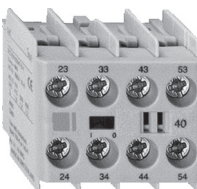
Auxiliary Contact Blocks	NO	NC	Contact Arrangement	Catalog Number
 <p>2-Pole</p> <p>Typical auxiliary contact block</p>	1	1		CA8-P11
	0	2		CA8-P02
	2	0		CA8-P20
	2	2		CA8-P22
	3	1		CA8-P31
 <p>4-Pole</p>	1	3		CA8-P13
	0	4		CA8-P04
	4	0		CA8-P40

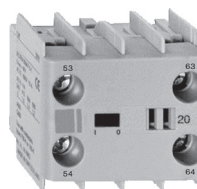
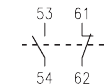
Auxiliary Contact Blocks	NO	NC	Contact Arrangement	Catalog Number
 <p>2-Pole</p> <p>Typical auxiliary contact block</p>	1	1		CS8-P11E
	0	2		CS8-P02E
	2	0		CS8-P20E
	2	2		CS8-P22Z
	3	1		CS8-P31Z
 <p>4-Pole</p>	1	3		CS8-P13E
	0	4		CS8-P04E
	4	0		CS8-P40E

G
CS8 Control Relays

Miscellaneous Accessories

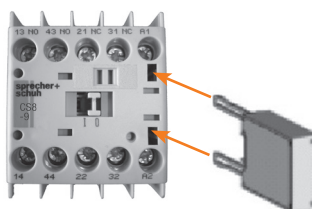
Accessory	Description	Catalog Number
	Surge Suppressor CR_8 - for limiting voltage spikes when switching off coil. Coil itself provides sufficient limitation at voltages over 240V.	CRC8-50 CRC8-280 CRC8-480
	RC Link (Type CRC8...) for AC Control 24-48VAC 110-280VAC 380-480VAC	
	Diode Link (Type CRD8...) for DC Control ② 12-250VDC (diode)	
	Varistor Link (Type CRV8...) for AC/DC Control 12-55VAC/12-77VDC 56-136VAC/78-180VDC 137-277VAC/181-250VDC	CRV8-55 CRV8-136 CRV8-277

① Auxiliary contact ratings per UL 508/NEMA (B600/Q600). Contacts are bifurcated (H-bridge) with a minimum current rating of 15V@2mA.

② CS8 relays with 24 VDC coils can be special ordered with integrated diodes (built-in) rather than applying CRD8 to the coil terminals.

③ Base relay with add-on auxiliaries meet mechanically linked IEC 60947-5-1 for CS8 DC coil versions only. See page G20 for additional information.

Technical Information

			CS8	Auxiliary Contacts
			B600, Q600	B600, Q600
Electrical				
Contact Ratings — NEMA				
Contact Ratings — IEC				
AC-15 (solenoids, contactors) at rated voltage	24...120V	[A]	3	3
	230...240V	[A]	2	2
	400V	[A]	1.2	1.2
IEC 947, EN 60947	480...500V	[A]	1	1
NEMA B600	600...690V	[A]	0.6	0.6
AC-12 (Rated thermal current)				
Ambient Temperature 40°C	I_{th} 24...690V	[A]	10	10
Ambient Temperature 60°C	I_{th} 24...240V	[A]	6	6
Low Level Signal Switching				
Contact design			H-bridge bifurcated	H-bridge bifurcated
Minimum switching recommendation			15V 2mA	15V 2mA
Short Circuit Protection				
Coordination Type 2 acc. IEC 947-5-1			Fuse gG [A]	10
Switching DC-13 (Q600)				
1 pole	24V	[A]	2.3	2.3
	48V	[A]	1	1
	110V	[A]	0.55	0.55
	125V	[A]	0.55	0.55
	220V	[A]	0.27	0.27
	250V	[A]	0.27	0.27
	400V	[A]	0.15	0.15
	440V	[A]	0.15	0.15
	600V	[A]	0.1	0.1
Load Carrying Capacity according to UL/CSA				
Rated voltage	AC	[V]	max. 600	max. 600
	DC	[V]	max. 600	max. 600
Continuous rating (40°C)	AC	[A]	10	10
Switching Capacity	AC	[A]	B600	B600
	DC	[A]	Q600	Q600
Continuous rating (general purpose)	300V	[V]	5	5
	600V	[V]	10	10
Resistance and Power Dissipation				
Main current circuit resistance, 1 pole		[mΩ]	6.5	6.5
Power dissipation I_{th} , 4 poles		[W]	2.6	2.6
Total Power dissipation				
I_{th}	AC control, warm	[W]	4.4	4.4
	DC control, warm	[W]	5.2	5.2

Mechanically Linked Contacts and Mirror Contact Performance

Type	Coil	Add-on Auxiliary Contact	Conforms to IEC	Status
CS8	AC or DC	None	60947-5-1	Mechanically linked within the base relay
	DC	Yes	60947-5-1	Mechanically linked within the base relay and with add-on auxiliary contacts
	AC	Yes	~	Mechanically linked within the base relay only

Definitions



- Mechanically linked contacts (IEC 60947-5-1 Annex L):
- N.C. Auxiliary Contact will not re-close if a N.O. power pole welds.
- N.O. Power Pole or Auxiliary Contact will not close if N.C. contact welds.
- The term "Positive Guided" contacts is the same as mechanically linked.

Technical Information

CS8 Relays			
Mechanical			
Mechanical Life	[Mil. Op]		15
Electrical Life			
AC-15 (240V, 2A) AC Operations	[Mil. Op]		0.7
Weight			
AC control	[kg/lbs]		0.16 (0.35)
DC control	[kg/lbs]		0.2 (0.44)

Terminations -
Main contacts and Auxiliary contacts



Terminal Type	Combination Screw Head: Cross, Slotted, Pozidrive		
 Fine stranded w/ ferrule	1 wire	[mm ²]	0.75...2.5
	2 wires	[mm ²]	0.75...2.5
 Solid or coarse stranded	1 wire	[mm ²]	1...4
	2 wires	[mm ²]	1...2.5 + 1...4
Max. Wire Size ①	[AWG]		18...12
Tightening Torque		[Nm]	1.2
		[lb-in]	10.6

Control Circuit			
Operating Voltage			
AC 50/60 Hz	Pickup	[x U _s]	0.85...1.1
	Dropout	[x U _s]	0.2...0.75
DC	Pickup	[x U _s]	0.8...1.1
		[x U _s]	9,12,24,110V DC: 0.7...1.25
with protection circuit	Dropout	[x U _s]	0.1...0.75
Coil Consumption			
AC 50/60 Hz	Inrush	[VA/W]	35/32
	Seal	[VA/W]	5/1.8
DC	Inrush/Seal	[W]	cold 3.0, warm 2.6
Operating Times			
AC- 50/60 Hz	Pickup Time	[ms]	15...40
	Dropout Time	[ms]	15...33
With RC module	Pickup Time	[ms]	15...28
DC	Pickup Time	[ms]	18...40
	Dropout Time	[ms]	6...12
With Integ. diode	Pickup Time	[ms]	8...12
With External diode	Pickup Time	[ms]	35...50

General		CS8 Relays	
Rated Voltage Withstand U			
IEC			690V
UL; CSA			600V
Rated Impulse Strength U_{imp}			
			6 kV
Rated Voltage U_e			
AC	[V]	24, 48, 120, 230, 400, 500, 600, 690	
DC	[V]	24, 48, 110, 220, 440V	
Rated Frequency			
			AC 50/60 Hz, DC
Ambient Temperature			
Storage			-55...+80°C (-67...176°F)
Operation at nominal current			-25...+60°C (-13...140°F)
At 85% rated operation current			-25...+70°C (-13... 158°F)
Resistance to Climatic Change			
			40° C (104° F), 95% relative humidity, 56 days
			23° C (73.4 ° F), 83%/40 °C (104 °F), 93%, 56 cycles
Altitude			
			2000m M.S.L., per IEC 60947-4-1
Type of Protection			
			IP2X
Standards			
			IEC/EN 60947-1, -5-1, -5-4; UL 508; CSA 22.2. No. 14
Approvals			
			UL File E33916



① Pozidrive No.2 / Blade No.3 screw

Series CS8 Industrial Control Relays

Dimensions are in millimeters (inches). Dimensions not intended for manufacturing purposes.

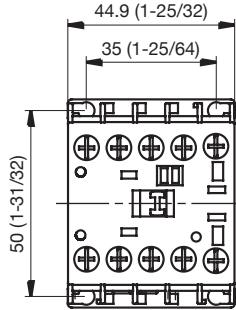

Mounting Position with Accessories

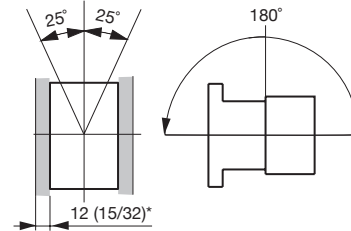

* Minimum distance to grounded parts or walls

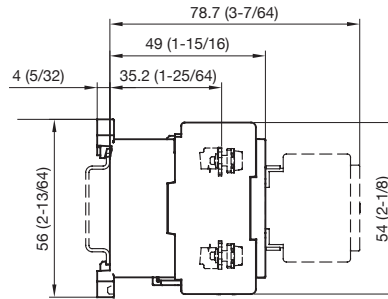

With front mount auxiliary

Contactor with...		Dim. [mm]	Dim. [inches]
with aux. contact block		78.7	3.1
with timer	on contactor	81.7	3.25
	at side of contactor	66.9	2.63
with neutral terminal	at side of contactor	64.9	2.56
with nameplate		51	2

RZ7-FS & RZ7-FE Electronic Timing Relays

Precision economical
DIN-rail mounted timing
relays



The RZ7-FS multifunction
Electronic Timing Relay



The RZ7-FE multifunction
Electronic Timing Relay



RZ7-FS

RZ7-FS timing relays are accurate to within 0.2 percent of the setting value. In addition, RZ7-FS relays function reliably -15% to +10% of rated voltage. RZ7-FS precision electronic timing relays offer 14 different output functions applicable to all types of industrial control. In addition to standard ON-Delay and OFF-Delay relays, the series also includes many special functions such as a true OFF-Delay that operates without supply voltage. Various timing ranges from 0.05 seconds to 300 hours are available.

RZ7-FS timing relays operate with multiple supply voltages ranging from 24-48VDC or 24-240VAC (some other voltages are available on multi-function and special function timers) The standard RZ7-FS is supplied with one single pole double throw (SPDT) contact within a compact case only 22.5mm wide. If more contacts are required, several relays are available that provide two separate, electrically isolated SPDT contacts within the same narrow footprint.

RZ7-FE

RZ7-FE electronic timing relays offer eight popular output functions in an economical package. This series is especially designed for applications where a high quality, yet basic timing relay is required. Timing formats include ON delay, OFF-delay, Wye-Delta and five other choices. All models are multi-time relays, meaning that various time ranges (from 0.05 seconds to 100 hours) can be selected from the face of the relay.

RZ7-FE timing relays operate with multiple supply voltages ranging from 24-48VDC or 24-240VAC (12-240VAC or DC on 2-pole multi-function). Universal voltage capability means smaller inventories and more flexibility. The RZ7-FE series has one single pole double throw (SPDT) contact. This series has several technical advantages such as shorter impulse duration requirements and a faster recovery time.

Features

- Each relay is equipped with LEDs that indicate supply of power and output status conditions.
- Finger and back of hand protection to IP40.
- Terminals are captive and supplied in the open position.
- RZ7's can be surface mounted, rail mounted, or mounted directly on our family of CA7/CS7 devices.
- RZ7 relays can be mounted in any-plane.
- Terminals, setting knob and LED's are all accessible from the front of the unit.
- RZ7 Timing Relays are very compact

G
RZ7 Timing Relays

Overview



RZ7-FS



RZ7-FE

Type	DIN Rail Timer	DIN Rail Timer
Features	<ul style="list-style-type: none"> • Only 22.5 mm wide • 5A contact rating • Multifunction or single function • Wye-delta timing function • True OFF-Delay timing function 	<ul style="list-style-type: none"> • Only 17.5 mm wide • 5 A contact rating • Multifunction or single function • Wye-Delta timing function
Control Outputs	SPDT or DPDT	SPDT
Operation Modes	A ON-Delay A+ Accumulative ON-Delay B OFF-Delay with Auxiliary Voltage C ON-Delay and OFF-Delay, Symmetrical D Impulse-ON E Impulse-OFF with Auxiliary Voltage F Flasher, Starting with ON FG Flasher, Starting with ON or OFF G Flasher Starting with OFF I Fixed Impulse with Adjustable Time Delay K One Shot with B1 L Pulse Former M Adjustable Impulse with Fixed Time Delay Q OFF-Delay without Auxiliary Voltage T ON/OFF-Function Y Wye-Delta Timing Relay Y1 Wye-Delta Change-over with Impulse Function	A ON-Delay B OFF-Delay D One shot E Fleeting OFF-Delay F Flasher, Repeat cycle-pulse G Flasher, Repeat Cycle Starting with Pause L Pulse converter, Pulse Former Y Wye-Delta Timing Relay
Time Range	0.05 s...300 hr	0.05 s... 100 hr
Supply Voltage	24V...48V DC 24V...240V AC 380...440V AC	24...48V DC 24...240V AC 12...240V AC/DC
Contact Rating at 120V AC	5 A	5 A
Certifications	cULus, CE, UKCA, C-tick	cULus, CE, UKCA, C-tick
Mounting	DIN Rail or panel mount	DIN Rail or panel mount

G
RZ7 Timing Relays

RZ7-FS Timing Relays
Single Function

Operating Mode	Contact Output	Timing Range ①	Input Voltage	Catalog Number
ON-Delay	(SPDT) 1 C/O	0.05 s...300 hr	24...48V DC 24...240V AC, 50/60 Hz	RZ7-FSA6UU23
	(DPDT) 2 C/O			RZ7-FSA7UU23
OFF-Delay	(SPDT) 1 C/O			RZ7-FSB6UU23
	(DPDT) 2 C/O			RZ7-FSB7UU23
One Shot w/B1	(SPDT) 1 C/O	RZ7-FSK6UU23		



Multi-Function This device allows the flexibility of selecting the appropriate timing function.

Operating Mode	Contact Output	Timing Range ①	Input Voltage	Catalog Number
Multi-function timing relays 10 Single-functions: A, A+, B, C, T, D, E, FG, L, and Y1 See function diagrams for further description.	(SPDT) 1 C/O	0.05 s...300 hr	24...48V DC 24...240V AC 50/60 Hz	RZ7-FSM6UU23
	(DPDT) 2 C/O			RZ7-FSM7UU23
				380...440V AC
Multi-function timing relays 7 Single-functions: A, T, D, I, M, F, and G See function diagrams for further description.	(DPDT) 2 C/O		24...48V DC 24...240V AC 50/60 Hz	RZ7-FSM8UU23

RZ7-FS High Performance Timing Relay

- Adjustable function and timing range timing relays
- DIN Rail mounted without cost of socket
- 22.5 mm wide multi-function or single functions
- Available as SPDT or DPDT contact output, 5A
- Timing Ranges From 0.05s...300 hr
- Coil Surge Protection

Special Function

Operating Mode	Contact Output	Timing Range ②	Input Voltage	Catalog Number
OFF-Delay without supply voltage	(SPDT) 1 C/O	0.05 s...10 min	24...240V DC 24...240V AC 50/60 Hz	RZ7-FSQ6QU18
	(DPDT) 2 C/O			RZ7-FSQ7QU18
Wye-Delta timing relay	2 C/O		24...48V DC 24...240V AC 50/60 Hz	RZ7-FSY7UU23
				380...440V AC

Accessories

Accessory	Description	Catalog Number
	Panel Mounting Adapter	RZ7-FSPMA
	Transparent Cover	RZ7-FSTC
IMPORTANT	Versatile Mounting: The RZ7-FS timing relay can be panel or DIN rail mounted. For best long-term performance, allow at least 10 mm (.04 in.) of space on each side of the relay for proper ventilation when operating in temperatures above 40 °C (104 °F).	

① Ten selectable timing ranges: 0.05...1 s, 0.15...3 s, 0.5...10 s, 1.5...30 s, 5...100 s, 15...300 s, 1.5...30 min, 15...300 min, 1.5...30 hr, 15...300 hr

② This time range is selectable in seven smaller ranges: 0.05 s...1 s, 0.15...3 s, 0.15 s...10 s, 1.5 s...30 s, 5...100 s, 15...300 s, 0.5...10 min

Function Diagrams - RZ7-FS Relays

(A) ON-Delay

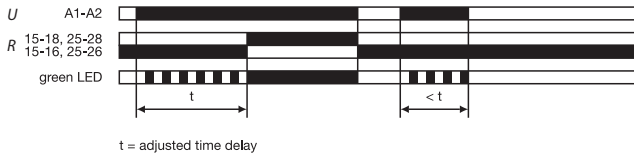

(A+) Accumulative ON-Delay

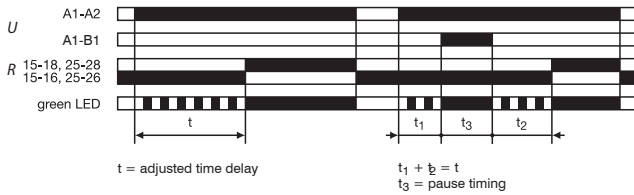

(B) OFF-Delay with Auxiliary Voltage

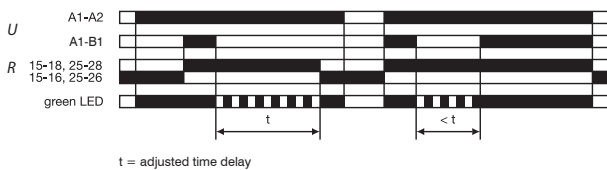

(C) ON-Delay and OFF-delay, Symmetrical

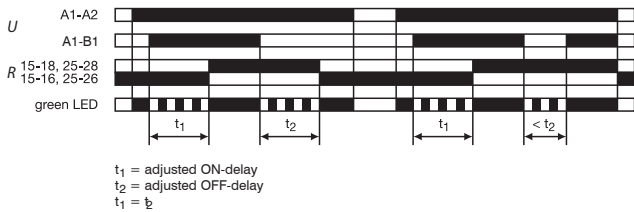

(D) Impulse-ON

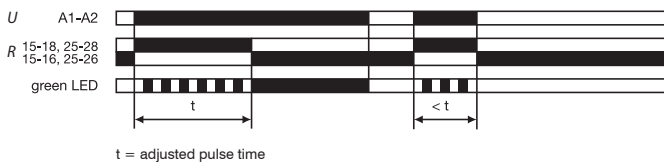

(E) Impulse-OFF with Auxiliary Voltage

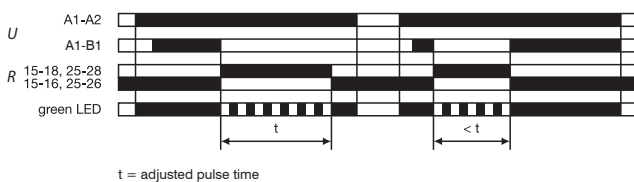

(F) Flasher, Starting with ON

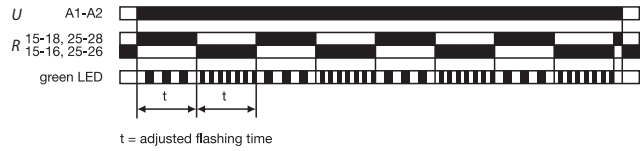

(FG) Flasher, Starting with ON or OFF

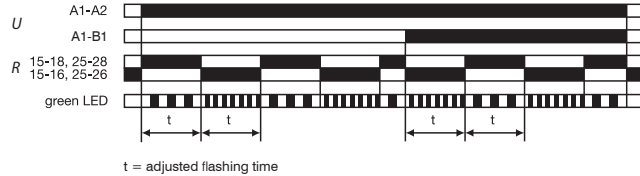

(G) Flasher, Starting with OFF

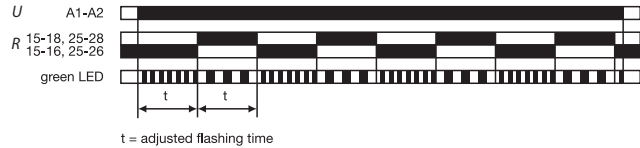

(I) Fixed Impulse with Adjustable Time Delay

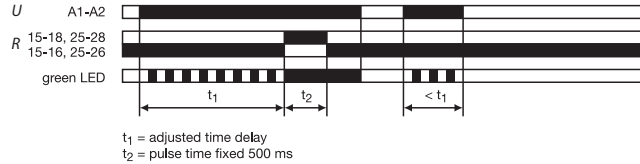

(K) One Shot with B1

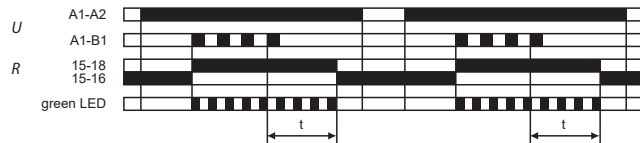

(L) Pulse Former

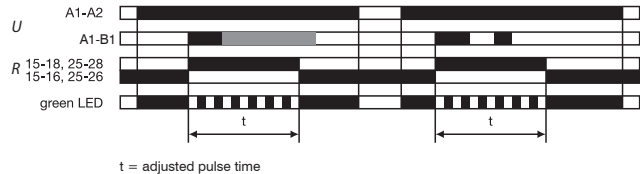

For timing control, a voltage other than the supply voltage can also be used.

Function Diagrams - RZ7-FS Relays - Continued

(M) Adjustable Impulse with Fixed Time Delay

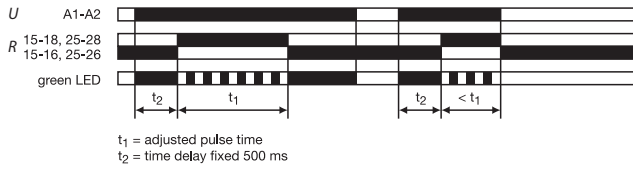

(Q) OFF-Delay without Auxiliary Voltage

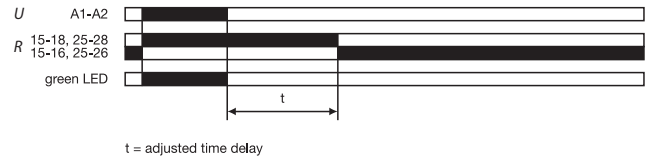

(T) ON/OFF-Function

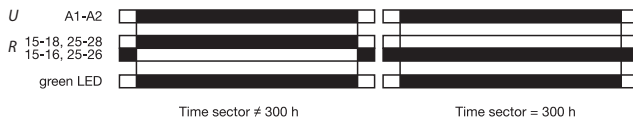

(Y) Wye-Delta Change-over

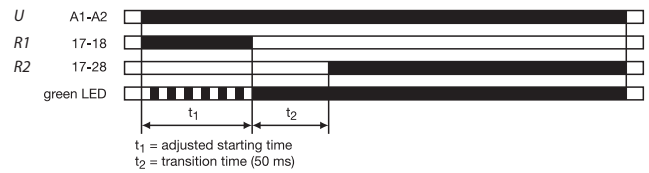

(Y1) Wye-Delta Change-over with Impulse Function

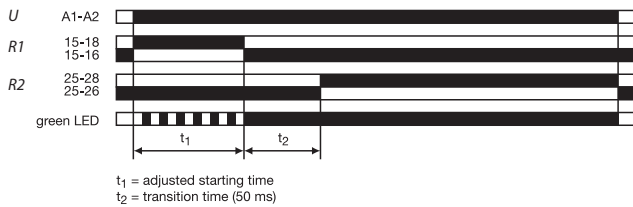

Legend

- U - green LED: control supply voltage applied / timing
- R - yellow LED: output relay energized

RZ7-FE Timing Relays

Single-Function This device offers you one specific timing function.

Time Range	Contact Output	Timing Range ①	Input Voltage	Catalog Number
ON-Delay	SPDT (1 C/O)	0.05 s...100 hr	24V...48V DC 24...240V AC 50/60 Hz	RZ7-FEA6TU23
OFF-Delay				RZ7-FEB6TU23
One Shot				RZ7-FED6TU23
Flasher (repeat cycle starting with pulse)				RZ7-FEF6TU23



RZ7-FE Economy Timing Relay

- Adjustable function and timing range timing relays
- DIN Rail mounted without cost of socket
- 17.5 mm wide, multi-function or single function
- SPDT contact output, 5 A
- Timing ranges from 0.05 s... 100 hr
- Coil Surge Protection

Multi-Function This device offers you the flexibility of selecting one of 7 single timing functions.

Operating Mode	Contact Output	Timing Range ①	Input Voltage	Catalog Number
Multi-function timing relays 7 Single-functions: A, B, D, E, F, G, and L See function diagrams for further description.	SPDT (1 C/O)	0.05 s...100 hr	24...48V DC 24...240V AC 50/60 Hz	RZ7-FEM6TU23
	DPDT (2 C/O)		12...240V AC/DC	RZ7-FEM6TZ12

Special Functions This device offers you one specific timing function.

Operating Mode	Contact Output	Timing Range ②	Input Voltage	Catalog Number
Wye-Delta	2 N.O. with 1 Common	0.15 s...10 min	24V...48V DC 24...240V AC 50/60 Hz	RZ7-FEY6QU23

Accessories

Accessory	Description	Catalog Number
	Panel Mounting Adapter	RZ7-FSPMA
IMPORTANT	Versatile Mounting: The RZ7-FE timing relay can be panel or DIN rail mounted. For best long-term performance, allow at least 10 mm (.04 in.) of space on each side of the relay for proper ventilation when operating in temperatures above 40 °C (104 °F).	

① Time ranges: 0.05...1 s, 0.5...10 s, 5...100 s, 0.5...10 min, 5...100 min, 0.5...10 h, 5...100 h

② Time ranges: 0.05...1 s, 0.5...10 s, 5...100 s, 0.5...10 min

Function Diagrams - RZ7-FE Relays

(A) ON-Delay

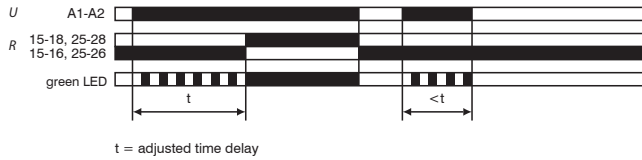

(B) OFF-Delay

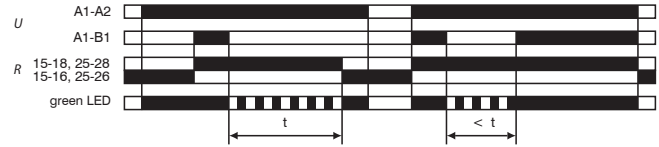

(D) One Shot [Impulse On]

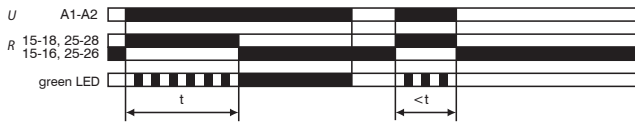

(F) Flasher [Repeat Cycle Starting with Pulse]

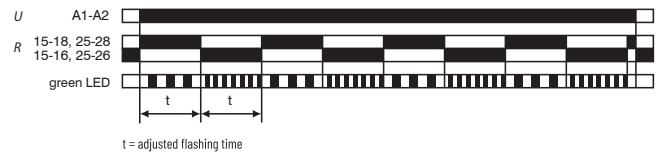

(E) Fleeting OFF-Delay [Impulse Off]

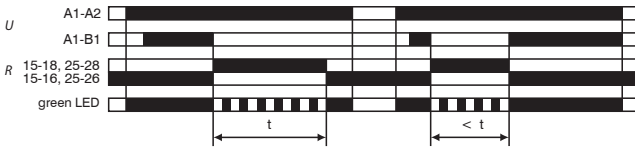

(L) Pulse Converter [Pulse Former]

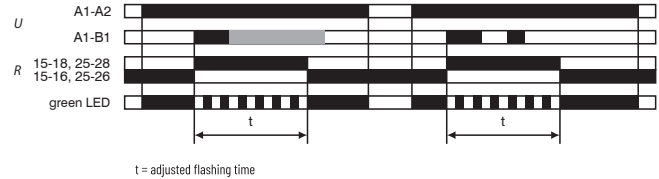

(Y) Wye-Delta Timing Relay

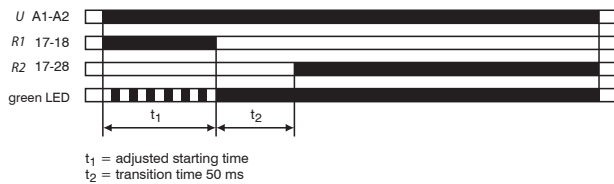

(G) Flasher [Repeat Cycle Starting with Pause]

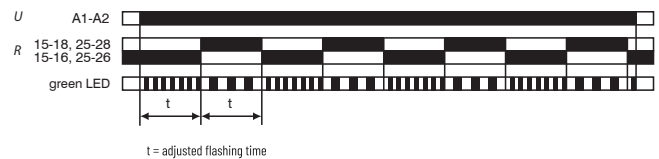

Legend

- U - green LED: control supply voltage applied / timing
- R - yellow LED: output relay energized

General Data	RZ7-FS Relays ①	RZ7-FE Relays ①
Insulation Characteristics	2 kVAC/50 Hz test voltage according to VDE 0435 and 4 kV 1.2/50 μs surge voltage according to IEC 60947-1 between all inputs and outputs	
EMC/Interference Immunity	Performance of following requirements: Surge capacity of the supply voltage according to IEC 61000-4-5: 2 kV Burst according to IEC 1000-4-4: 6 kV 6/50 ns ESD discharge according to IEC 61000-4-2: Contact 6 kV, air 8 kV	The following requirements are fulfilled: Surge capacity of the supply voltage according to IEC 61000-4-5: Level 4 Burst according to IEC 61000-4-4: Level 3 ESD discharge according to IEC 61000-4-2: Level 3
EMC/Emission	Electromagnetic fields according to EN 55 022: class B	
Safe Isolation	According to VDE 106, part 101	
Relative Humidity	25... 85%	
Vibration Resistance, operating	1 G	
Vibration Resistance, nonoperating	4 G	
Shock Resistance, operating	7 G	
Shock Resistance, nonoperating	50 G	
Weight	100g	60g
Ambient Temperature, operating	-25...+60 °C	
Ambient Temperature, nonoperating	-40...+85 °C	
Control Terminals	Tightening torque (0.6...0.8 Nm) 1 x 0.5...4.0 mm ² or 2 X0.5...2.5 mm ² (solid) 1 x 18...14 AWG or 2 x 18...16 AWG (stranded) Finger protection according to EN 50274	Tightening torque (0.5...0.8 Nm) 1 x 0.5...4.0 mm ² or 2 X0.5...2.5 mm ² (solid) 1 x 18...14 AWG or 2 x 18...16 AWG (stranded) Finger protection according to EN 50274
Panel Mounting	Front mounting; For snap-on mounting on 35 mm DIN Rail or screw fixing by panel mounting adapter and 2 screws (M4 type)	
Certifications	cULus Listed (File No. E14840, Guide NKCR/NKCR7), CE Marked, UKCA, C-tick	
Standards	EN/IEC 60947-1 EN/IEC 60947-5-1 UL 508 CAN/CSA C22.2 No.14	IEC/EN 63000 IEC 61812-1 UL 508 CAN/CSA C22.2 No.14

① Time Characteristics (according to VDE 0435, Part 2021)

Specifications		RS7-FS Relays ①	RS7-FE Relays ①
Setting Accuracy		±6% of full scale	±10% of full scale
Repeatability		±0.2% of the setting values	±0.5% of setting (typical)
Tolerance		Voltage: ±0.004%/V Temperature: ±0.035%/°C	Voltage: ±0.001%/ΔU Temperature: ±0.025%/°C
Supply			
Supply Voltages		24...48V DC and 24...240V AC, 50/60 Hz (multi voltage)	24...48V DC and 24...240V AC, 50/60 Hz
Voltage Tolerance		-15%/+10% AC/DC	
Power Consumption		Max 16 VA	max 3.5 VA
Time Energized		100%	
Reset Time		<80 ms	50 ms
Cable Length (Supply Voltage Control)		Max. 50 m	
Pulse Control (B1)			
Pulse Duration		≥20 ms	
Input Voltage		Supply voltage range	
Input Current		1 mA	
Cable Length		Max. 50 m	
Outputs			
Contact Type		2 Form C - DPDT contacts, 1 Form C - SPDT contacts	1 Form C - SPDT contact
Dielectric Withstand Voltage	Contact-to-coil	6000V	4000V
	Power	500V AC	3600 VA (Make) 360 VA (Break)
Switching Capacity	According to IEC 947-5-1	3 A/230V AC (inductive load, AC 15)	4 A /230V AC (resistive load, AC-12)
		2 A/24V DC (inductive load, DC 13)	0.2 A/230V AC (inductive load, AC 15)
	According to UL 508:	1.5 A/250V AC (B300) - 3 A/120V AC (B300)	1 A/24V DC (inductive load, DC 13)
Short circuit protective device		N/C 6 A, N/O 10 A (Fast Blow Fuse)	
Life	Mechanical	30 million operations	
	Electrical	100,000 operations at AC12, 230V, 4 A	min 100,000 operations
State Indicator		2 LED, combination signal	

① Time Characteristics (according to VDE 0435, Part 2021)

Series RZ7-FS Timing Relays

Dimensions are in inches (millimeters).
Dimensions not intended for manufacturing purposes.

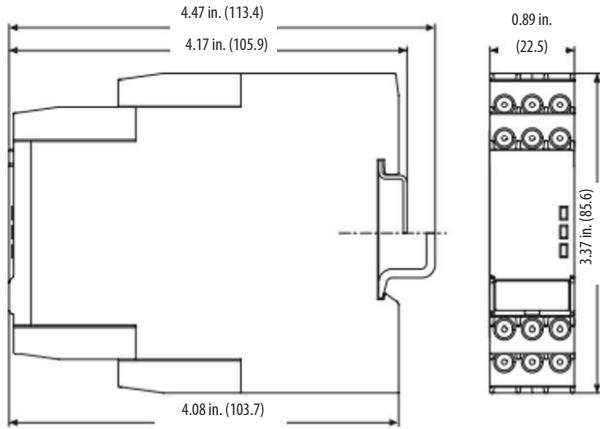

RZ7-FS

Panel Mounting Adapter

Dimensions are in inches (millimeters).
Dimensions not intended for manufacturing purposes.

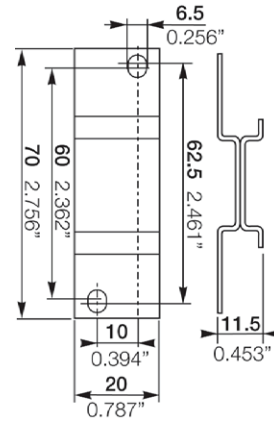

RZ7-FSPMA

Series RZ7-FE Timing Relays

Dimensions are in inches (millimeters). Dimensions not intended for manufacturing purposes.

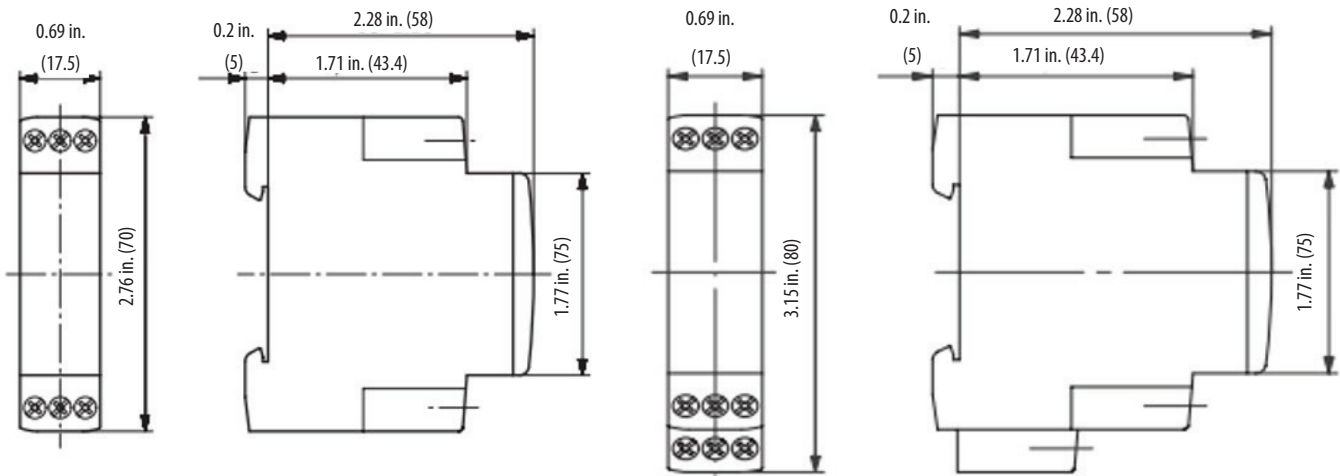

RZ7-FE with 1 c/o Contact or 2 n/o Contacts

RZ7-FE with 2 c/o Contact

RZ7-FS Electronic Timing Relays

Precision DIN-rail
mounted timing relays
for any industrial
application



DISCONTINUED

Sprecher + Schuh's RZ7-FS precision electronic timing relays offer 19 different output functions applicable to all types of industrial control. In addition to standard ON-Delay and OFF-Delay relays, the series also includes many specials such as an OFF-Delay that operates without supply voltage. Various timing ranges from 0.05 seconds to 60 hours are available, with many relays offering multi-time setting capability in the same device.

Solid state accuracy and reliability

Except for their hard silver contacts, all RZ7-FS timing relays are built with solid state electronics and controlled by a microprocessor. They are accurate to within 0.2 percent. Their ruggedness and high level of accuracy is due to the thorough testing of function, timing characteristics and surge voltage strength performed on each device prior to shipment.

In addition, RZ7-FS relays function reliably from 15% under rated operating voltage to 10% over rated voltage (AC). Voltage tolerance is even greater in DC applications.

Eliminates additional relays

The standard RZ7-FS is supplied with one single pole double throw (SPDT) contact within a compact case only 22.5mm wide. If more contacts are required, several relays are available that provide two separate, electrically isolated SPDT contacts within the same narrow footprint. Output two is selectable as an instantaneous contact, which can eliminate the need for auxiliary relays in complex installations. These two pole relays can also be used with an external potentiometer for remote time setting.



The multifunction RZ7-FSM Electronic Timing Relay provides eight different timing functions and ten different timing ranges.



Multiple functions and timing ranges in one relay

The RZ7-FSM combines *eight* separate timing functions (plus ON and OFF functions) into one device. In addition, ten timing ranges are individually selectable from 0.05 seconds to 60 hours. These special relays reduce inventories and are ideal for maintaining remote installations where stocking several different timing relays would not be practical.

Many safety and convenience features

- Every RZ7 accepts a broad range of AC and DC supply voltages without special ordering.
- Each relay is equipped with an LED that indicates four output status conditions.
- Finger and back of hand protection to IP40.
- Terminals are captive and supplied in the open position.
- All RZ7's can be surface mounted, rail mounted, or mounted directly on our family of CA7/CS7 or CA8/CS8 devices.
- RZ7 relays can be mounted in any plane.
- Terminals, setting knob and LED's are all accessible from the front of the unit.
- RZ7 Timing Relays are very compact, measuring approximately 1" x 3" x 4".
- Hazardous location timing relays also available.

G
RZ7 Timing Relays

Quick Selection Guide

Single Function Timing Relays				
RZ7-FS	A	3	A	U23
Type	Function	Contacts	Time Ranges	Supply Voltages
	A On-Delay B Off-Delay C On and Off-Delay D One Shot / Watchdog E Fleeting Off-Delay F Symmetric flasher starting with a pulse G Symmetric flasher starting with a pause I On-Delay pulse generator J On-Delay (pulse controlled) K One Shot / Watch Dog (pulse controlled) L Impulse Converter	<i>All functions:</i> 3 One single pole double throw contact <i>Functions A & B only:</i> 4 Two single pole double throw contacts ② (Available with Time Range "U" only. Not available with "U18" supply voltage)	A 0.05...1 second B 0.15...3 seconds C 0.5...10 seconds D 1.5...30 seconds E 0.05...1 minute F 0.15...3 minutes G 0.5...10 minutes H 1.5...30 minutes I 0.05...1 hour J 0.15...3 hours K 0.5...10 hours L 3.0...60 hours U 0.05s...60 hours ①	<i>Standard:</i> U23 24...48VDC 24...240V 50/60Hz <i>Special Order:</i> U18* 24...240VAC or DC A40 346...440V 50/60Hz ③ Z12 12VDC * Not available with Time Range "U"
RZ7-FS	Q	3	Q	U18
Type	Function	Contacts	Time Ranges	Supply Voltages
	Q Off-Delay Without Supply Voltage	3 One single pole double throw contact 4 Two single pole double throw contacts ②	Q 0.15s...10 minutes ①	U18 24...240VAC or DC

Multi-Function Timing Relay				
RZ7-FS	M	3	U	U23
Type	Function	Contacts	Time Ranges	Supply Voltages
	M Multi-Function <i>Eight single functions plus ON & OFF function (for installation/maintenance)</i> - On-Delay - Off-Delay - On and Off-Delay - One Shot / Watchdog - Fleeting Off-Delay - Symmetric flasher starting with a pulse	3 One single pole double throw contact 4 Two single pole double throw contacts ②	U 0.05...60 hours ①	<i>Standard:</i> U23 24...48VDC 24...240V 50/60Hz <i>Special Order:</i> U18 24...240VAC or DC A40 346...440V 50/60Hz ③ Z12 12VDC

Special Function Timing Relays				
RZ7-FS	H	3	U	U23
Type	Function	Contacts	Time Ranges	Supply Voltages
	H Repeat Cycle Timer (Flasher) <i>Includes four separate functions</i> - Supply voltage controlled, output starts with a pause - Supply voltage controlled, output starts with a pulse - Pulse controlled, output starts with a pause - Pulse controlled, output starts with a pulse	<i>All functions:</i> 3 One single pole double throw contact	<i>For equal timing of pulse and pause</i> U 0.05s...60 hours ① <i>For separate timing of pulse and pause</i> V 2 x 0.05s...60 hours ①	<i>Standard:</i> U23 24...48VDC 24...240V 50/60Hz <i>Special Order:</i> A40 346...440V 50/60Hz ③ Z12 12VDC
RZ7-FS	Y	2	C	U23
Type	Function	Contacts	Time Ranges	Supply Voltages
	Y Wye Delta Timing Relay	2 Two normally open contacts	C 0.5...10 seconds D 1.5...30 seconds E 0.05...1 minute F 0.15...3 minutes G 0.5...10 minutes	<i>Standard:</i> U23 24...48VDC 24...240V 50/60Hz <i>Special Order:</i> A40 346...440V 50/60Hz ③

① Multi-time setting range. See Technical Section for specific time settings.
 ② Second output selectable as timed or instantaneous.

③ Timers with supply voltage code A40 (346...440VAC) are not UL listed. RZ7-FSx4 models are not available with supply voltage code A40.

Illustration for reference only. See selection tables for specific catalog numbers.

RZ7 Timing Relays

RZ7-FS Timing Relays – Single Function, One and Two Pole

Functional Description	Functional Diagram	Terminal Arrangement	Type	Catalog Number
ON-Delay Timing Relay (A) When supply voltage is applied, output contact(s) change state after time delay <i>t</i> .			<ul style="list-style-type: none"> • One SPDT contact • Single timing range 	RZ7-FSA3*U23
			<ul style="list-style-type: none"> • One SPDT contact • Multi-timing range (from 0.05s to 60h) ④ 	RZ7-FSA3UU23
OFF-Delay Timing Relay (B) When control contact "S" closes, output contact(s) change state immediately. When control contact S opens, output contact(s) change state after time delay <i>t</i> . Constant supply voltage required on terminals A1/A2.			<ul style="list-style-type: none"> • One SPDT contact • Single timing range 	RZ7-FSB3*U23
			<ul style="list-style-type: none"> • One SPDT contact • Multi-timing range (from 0.05s to 60h) ④ 	RZ7-FSB3UU23
Off-Delay Without Supply Voltage (Q) ⑥ When supply voltage is applied, output contact(s) change state immediately. When supply voltage is removed, output contact(s) change state after time delay <i>t</i> .			<ul style="list-style-type: none"> • One SPDT contact • Multi-timing range (from 0.15s to 10min) ⑥ 	RZ7-FSQ3QU18
			<ul style="list-style-type: none"> • Two SPDT contacts • Multi-timing range (from 0.15s to 10min) ⑥ 	RZ7-FSQ4QU18

G
RZ7 Timing Relays

Supply Voltage

Single Function RZ7-FS...U23 timers (except RZ7-FSQ) accept supply voltages of 24...48VDC and 24...240VAC (RZ7-FSQ accepts 24...240VAC or DC). Other voltages are available by special order. See Quick Selection Guide on page G24 for details or contact your Sprecher + Schuh representative for information.

- ① For timing control, a voltage other than the supply voltage can also be used.
- ② Output two is selectable as an instantaneous contact by sliding a switch on the faceplate.
- ③ Bridge or potentiometer 10kΩ, min. 0.25W (low voltage) for external time setting.
- ④ Timing range is screwdriver selectable from the faceplate. Timing range selections include those found in the Timing Range Code chart.
- ⑤ Timing range is screwdriver selectable from the faceplate. Exact timing ranges can be found in the Technical Section.
- ⑥ Due to shock during shipment, the state of the contacts should be verified before initial use.

Timing Range Codes

Replace (*) with Timing Range Code

Timing Range	Code
0.05...1 sec	A
0.15...3 sec	B
0.5...10 sec	C
1.5...30 sec	D
0.05...1 min	E
0.15...3 min	F
0.5...10 min	G
1.5...30 min	H
0.05...1 hour	I
0.15...3 hour	J
0.5...10 hour	K
3.0...60 hour	L



RZ7-FS two pole timing relay

RZ7-FS Timing Relays – Single Function, One Pole

Functional Description	Functional Diagram	Terminal Arrangement	Type	Catalog Number
<p>ON and OFF-Delay Timing Relay (C) When control contact "S" closes, output contact changes state after time delay t. When control contact S opens, output contact changes state again after time delay t. Constant supply voltage required on terminals A1/A2.</p> <p><i>Note:</i> Closure duration of S must be greater than t.</p>			<ul style="list-style-type: none"> • One SPDT contact • Single timing range 	RZ7-FSC3*U23
<p>One Shot / Watchdog Relay (D) When supply voltage is applied, the output contact changes state for time period t.</p>			<ul style="list-style-type: none"> • One SPDT contact • Single timing range 	RZ7-FSD3*U23
<p>Fleeting OFF-Delay Timing Relay (E) When control contact "S" is pulsed, output contact changes state for time period t.</p> <p><i>Note:</i> Control pulse duration minimum 50ms (AC) - 30ms (DC).</p>			<ul style="list-style-type: none"> • One SPDT contact • Single timing range 	RZ7-FSE3*U23
<p>Symmetric Flasher Starting With A Pulse (F) When supply voltage is applied, output contact changes state immediately and then repeatedly changes after every time period t, continuing until supply voltage is removed.</p>			<ul style="list-style-type: none"> • One SPDT contact • Single timing range 	RZ7-FSF3*U23

G
RZ7 Timing Relays

Supply Voltage

Single Function RZ7-FS...U23 timers accept supply voltages of 24...48VDC and 24...240VAC. Other voltages are available by special order. See Quick Selection Guide on page G24 for details or contact your Sprecher + Schuh representative for information.

Timing Range Codes

Replace (*) with Timing Range Code

Timing Range	Code
0.05...1 sec	A
0.15...3 sec	B
0.5...10 sec	C
1.5...30 sec	D
0.05...1 min	E
0.15...3 min	F
0.5...10 min	G
1.5...30 min	H
0.05...1 hour	I
0.15...3 hour	J
0.5...10 hour	K
3.0...60 hour	L



RZ7-FS one pole timing relay

① For timing control, a voltage other than the supply voltage can also be used.

RZ7-FS Timing Relays – Single Function, One Pole

Functional Description	Functional Diagram	Terminal Arrangement	Type	Catalog Number
<p>Symmetric Flasher Starting With A Pause (G)</p> <p>When supply voltage is applied, output contact changes state after time period t and then repeatedly changes again after every period t, continuing until supply voltage is removed.</p>			<ul style="list-style-type: none"> • One SPDT contact • Single timing range 	RZ7-FSG3*U23
<p>On-Delay Pulse Generator (I)</p> <p>When supply voltage is applied, output contact changes state after time period t. Output contact changes state again after 0.5 seconds.</p>			<ul style="list-style-type: none"> • One SPDT contact • Single timing range 	RZ7-FSI3*U23
<p>On-Delay (pulse controlled) (J)</p> <p>When control contact "S" is pulsed, the output contact changes state after time period t.</p>			<ul style="list-style-type: none"> • One SPDT contact • Single timing range 	RZ7-FSJ3*U23
<p>One Shot / Watchdog (pulse controlled) (K)</p> <p>When control contact "S" closes, the output contact changes state immediately. After the last pulse of contact S, the output contact changes state after time delay t.</p>			<ul style="list-style-type: none"> • One SPDT contact • Single timing range 	RZ7-FSK3*U23
<p>Impulse Converter (L)</p> <p>When a pulse is applied to control contact "S", the output contact changes state immediately for time period t. Pulses received during timing period t have no further effect.</p> <p><i>Note: The period t is not dependent on the length of the control pulse. Control pulse duration minimum 50ms (AC) - 30ms (DC).</i></p>			<ul style="list-style-type: none"> • One SPDT contact • Single timing range 	RZ7-FSL3*U23

G
RZ7 Timing Relays

Supply Voltage

Single Function RZ7-FS..U23 timers accept supply voltages of 24...48VDC and 24...240VAC. Other voltages are available by special order. See Quick Selection Guide on page G24 for details or contact your Sprecher + Schuh representative for information.

Timing Range Codes

Replace (*) with Timing Range Code

Timing Range	Code
0.05...1 sec	A
0.15...3 sec	B
0.5...10 sec	C
1.5...30 sec	D
0.05...1 min	E
0.15...3 min	F
0.5...10 min	G
1.5...30 min	H
0.05...1 hour	I
0.15...3 hour	J
0.5...10 hour	K
3.0...60 hour	L



RZ7-FS one pole timing relay

① For timing control, a voltage other than the supply voltage can also be used.

RZ7-FS Timing Relays – Multi-Function, One and Two Pole

RZ7-FSM Multi-Function Relay	Functional Description	Type	Catalog Number
	<p>Multi-Function Relay (M) The RZ7-FSM multifunction relay combines <i>eight</i> timing functions plus ON and OFF functions (for installation and maintenance). Each timing function and timing range is selectable from the face of the relay with a screwdriver actuated knob. The RZ7-FSM offers the following timing functions:</p> <p>On-Delay On and Off-Delay Fleeting Off-Delay On-Delay Pulse Generator ON Function (see below) OFF Function (see below)</p> <p>Off-Delay One Shot / Watchdog Impulse Converter Symmetric Flasher Starting With a Pulse With a Pulse</p> <p>The two pole RZ7-FSM4 offers two separate, electrically isolated single pole double throw (SPDT) contacts which allow applications in complex installations without additional auxiliary relays. This series may also be operated remotely via an external potentiometer.</p>	<ul style="list-style-type: none"> • One SPDT contact • Multifunction, multi-timing range relay (from 0.05s to 60h) ④ 	RZ7-FSM3UU23
		<ul style="list-style-type: none"> • Two SPDT contacts ② • Multifunction, multi-timing range relay (from 0.05s to 60h) ④ 	RZ7-FSM4UU23

RZ7 Timing Relays

On-Delay (A)

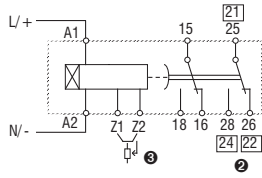
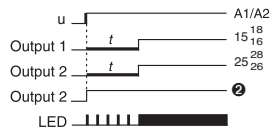

Off-Delay (B)

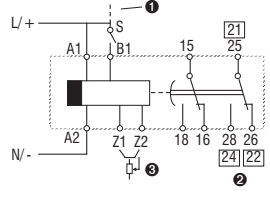
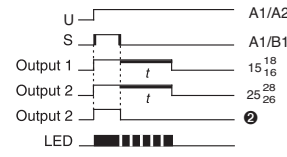

On and Off-Delay (C)

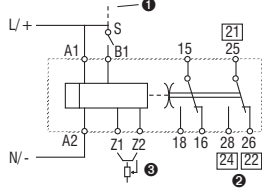
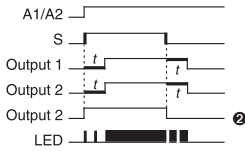

One Shot / Watchdog (D)

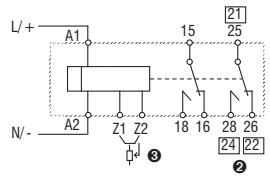
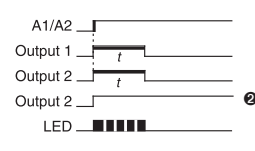

Fleeting Off-Delay (E)

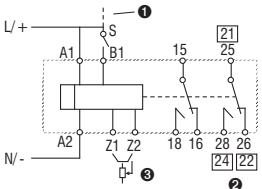
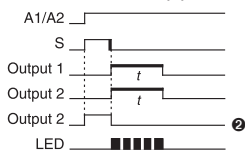

Symmetric Flasher Starting With a Pulse (F)

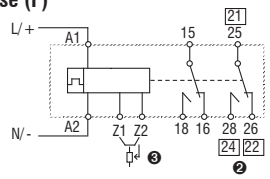
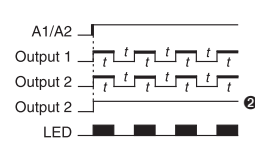

On-Delay Pulse Generator (I)

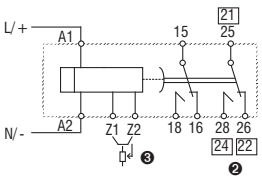
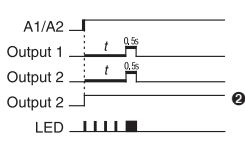

Impulse Converter (L)

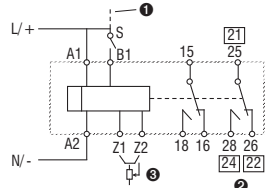
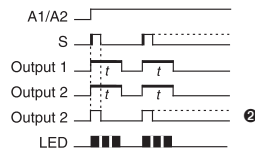

ON-Function

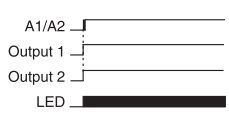

OFF-Function

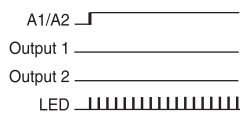

Function display LED (Green)

- Output in rest position, no timing
- ▄▄▄▄▄▄▄▄ Output in rest position, time running
- ▀▀▀▀▀▀▀▀ Output in operation position, no timing
- ▄▄▄▄▄▄▄▄ Output in operation position, time running

Supply Voltage

The RZ7-FSM timer accepts supply voltages of 24...48VDC and 24...240VAC. Other supply voltages are available by special order. See Quick Selection Guide on page G24 for details or contact your Sprecher + Schuh representative for information.

- ① For timing control, a voltage other than the supply voltage can also be used.
- ② Output two is selectable as an instantaneous contact by sliding a switch on the faceplate.
- ③ Bridge or potentiometer 10kΩ, min. 0.25W (low voltage) for external time setting.
- ④ Function selection and timing range is screwdriver selectable from the faceplate. Exact timing range selections can be found in Technical Information.

RZ7-FS Timing Relays – Special Function, One Pole

Functional Description	Functional Diagram	Terminal Arrangement	Type	Catalog Number
<p>Wye-Delta Timing Relay (Y) When supply voltage is applied, output contact Y closes for time period t. After time period t, plus a fixed time period t_u, (50-65ms) output contact Δ closes.</p>			<ul style="list-style-type: none"> • Two single pole N.O. contacts • Single timing range 	RZ7-FSY2*U23
<p>Repeat Cycle Timer (H) - (Flasher) The Repeat Cycle Timer offers four different operating characteristics within the same relay. Depending on how the unit is wired, cycles are initiated either by supply voltage being applied or by a pulse from control contact "S". Regardless of the activation method, each cycle may begin with a pause or a pulse.</p>	<p><i>Supply voltage controlled, output starts with a pause Switch is up</i></p>		<ul style="list-style-type: none"> • One SPDT contact • Multi-timing range (from 0.05s to 60h) ② <p>Provides (1) range setting for t_1 and t_2</p> <p>Provides (2) range settings for t_1 and t_2</p>	RZ7-FSH3UU23
<p>The RZ7-FSH3U relay sets the pulse and pause durations within one timing range setting. The RZ7-FSH3V allows individual time settings of pulse and pause within two timing range settings. Both relays offer multiple time settings between 0.05s and 60h, selectable in ten increments.</p>	<p><i>Supply voltage controlled, output starts with a pulse Switch is down</i></p>			RZ7-FSH3UU23
	<p><i>Pulse controlled, output starts with a pause Switch is up</i></p>			RZ7-FSH3VU23
	<p><i>Pulse controlled, output starts with a pulse Switch is down</i></p>			RZ7-FSH3VU23

G
RZ7 Timing Relays

Supply Voltage

These timers accept supply voltages of 24...48VDC and 24...240VAC. A supply voltage of 346...440VAC is also available by special order. See Quick Selection Guide on page G24 for details or contact your Sprecher + Schuh representative for information.

Timing Range Codes

Replace (*) with Timing Range Code

Timing Range	Code
0.5...10 sec	C
1.5...30 sec	D
0.05...1 min	E
0.15...3 min	F
0.5...10 min	G

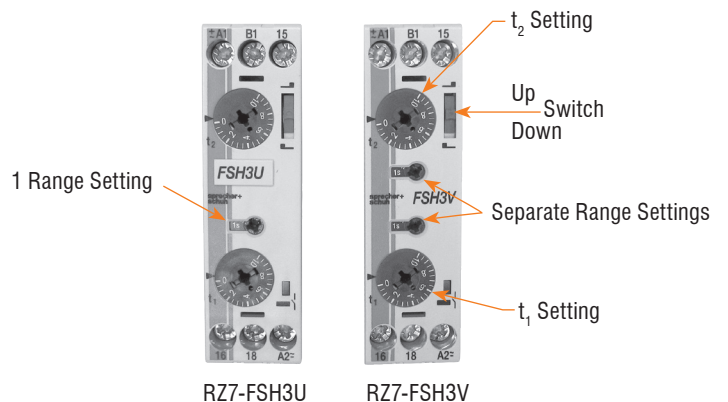

① For timing control, a voltage other than the supply voltage can also be used.
② Timing range is screwdriver selectable from the faceplate. Exact timing range selections can be found in Technical Information.

RZ7 Hazardous Location Electronic Timing Relays

Sprecher+Schuh's RZ7 hazardous location relay timers have been designed to meet the stringent requirements of hazardous location applications while maintaining the functionality of the existing RZ7-FS family of timing relays. The RZ7-FSM4...-EX is a multi-function timing relay with 8 single-functions, SPDT or DPDT contact output, and adjustable timing ranges. The -EX models are ideal for control panels installed in hazardous location areas such as in the oil, gas and petrochem industries.



Multiple Approvals



- cULus Industrial Control Equipment for Hazardous Location Listed 87SL
- UL Class 1, Div. 2, Groups A,B,C,D
UL Class 1, Zn 2, Group IIC
- Temperature Code T4A,
- 2A 32VDC max.

G
RZ7 Timing Relays

RZ7-FS Hazardous Location Timing Relay – Single Function, One Pole ②

Functional Description	Functional Diagram	Terminal Arrangement	Type	Catalog Number
<p>One Shot / Watchdog (pulse controlled) (K) When control contact "S" closes, the output contact changes state immediately. After the last pulse of contact S, the output contact changes state after time delay <i>t</i>.</p>			<ul style="list-style-type: none"> • One SPDT contact • Single timing range 0.05...1 second 0.5...10 second 	<p>RZ7-FSK3AU23-EX RZ7-FSK3CU23-EX</p>

Supply Voltage

Single Function RZ7-FSK3...-EX timers accept supply voltages of 24...48VDC and 24...240VAC.

① For timing control, a voltage other than the supply voltage can also be used.
② Technical data and dimensional information for the RZ7-FS...-EX models are the same as the standard RZ7-FS models.

RZ7-FS Hazardous Location Timing Relays – Multi-Function, One and Two Pole

RZ7-FSM Multi-Function Relay	Functional Description	Type	Catalog Number
	<p>Multi-Function Relay (M) The RZ7-FSM multifunction relay combines <i>eight</i> timing functions plus ON and OFF functions (for installation and maintenance). Each timing function and timing range is selectable from the face of the relay with a screwdriver actuated knob. The RZ7-FSM offers the following timing functions:</p> <p>On-Delay Off-Delay On and Off-Delay One Shot / Watchdog Fleeting Off-Delay Impulse Converter On-Delay Pulse Generator Symmetric Flasher Starting ON Function (see below) With a Pulse OFF Function (see below)</p> <p>The two pole RZ7-FSM4 offers two separate, electrically isolated single pole double throw (SPDT) contacts which allow applications in complex installations without additional auxiliary relays. This series may also be operated remotely via an external potentiometer.</p>	<ul style="list-style-type: none"> One SPDT contact Multifunction, multi-timing range relay (from 0.05s to 60h) ④ 	RZ7-FSM3UU23-EX
		<ul style="list-style-type: none"> Two SPDT contacts ② Multifunction, multi-timing range relay (from 0.05s to 60h) ④ 	RZ7-FSM4UU23-EX

On-Delay (A)

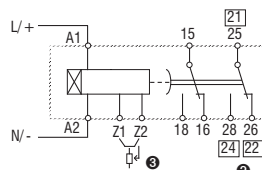
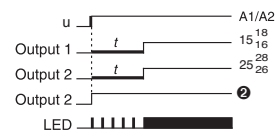

Off-Delay (B)

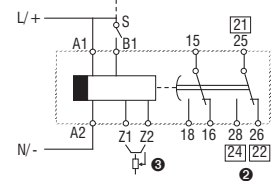
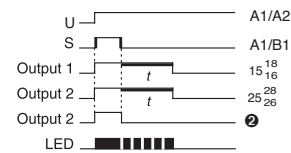

On and Off-Delay (C)

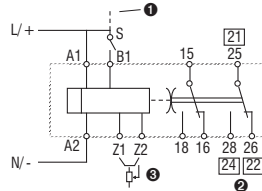
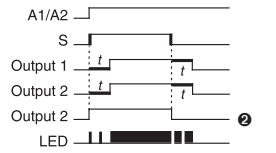

One Shot / Watchdog (D)

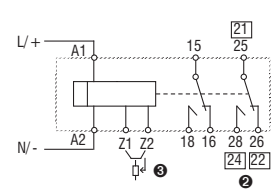
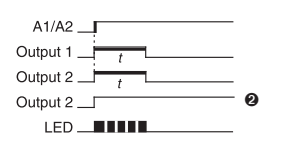

Fleeting Off-Delay (E)

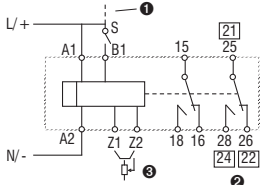
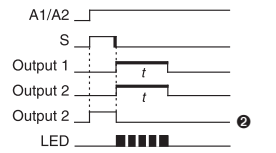

Symmetric Flasher Starting With a Pulse (F)

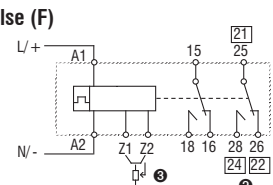
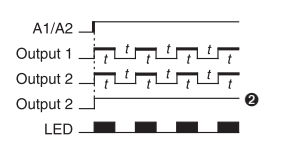

On-Delay Pulse Generator (I)

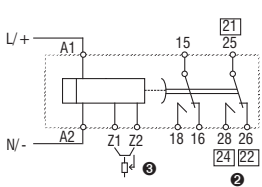
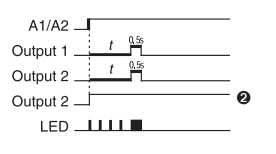

Impulse Converter (L)

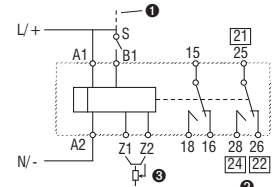
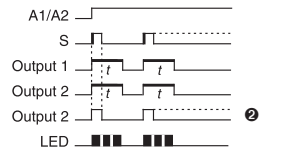

ON-Function

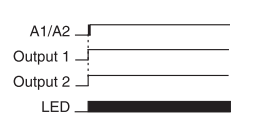

OFF-Function

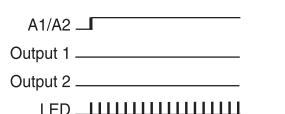

Function display LED (Green)

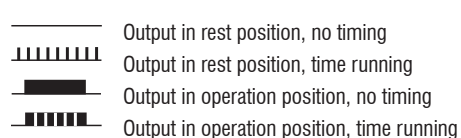

Supply Voltage

The RZ7-FSM timer accepts supply voltages of 24...48VDC and 24...240VAC.

- ① For timing control, a voltage other than the supply voltage can also be used.
- ② Output two is selectable as an instantaneous contact by sliding a switch on the faceplate for RZ7-FSM4 model.
- ③ Bridge or potentiometer 10kΩ, min. 0.25W (low voltage) for external time setting for RZ7-FSM4 model.
- ④ Function selection and timing range is screwdriver selectable from the faceplate. Exact timing range selections can be found in Technical Information.
- ⑤ Technical data and dimensional information for the RZ7-FS...-EX models are the same as the standard RZ7-FS models.

G
RZ7 Timing Relays

RZ7-FE Electronic Timing Relays

The economical choice for most industrial timing applications



RZ7 Timing Relays



The RZ7-FEM multifunction timing relay combines all functions in one device.

DISCONTINUED
Sprecher + Schuh's RZ7-FE electronic timing relays offer seven popular output functions in an economical package. This series is especially designed for applications where a high quality, yet basic timing relay is required. Timing formats include ON-delay, OFF-delay, Wye-Delta and four other choices. All models are multi-time relays, meaning that various time ranges (from 0.05 seconds to 10 hours) can be selected from the face of the relay.

Solid state accuracy and reliability

Except for their hard silver contacts, all RZ7-FE timing relays are built with solid state surface mounted electronics and are accurate to within one percent. Their ruggedness and accuracy is due to the thorough testing of function, timing characteristics and surge voltage strength performed on *each device* prior to shipment.

In addition, RZ7-FE relays function reliably from 15% under rated operating voltage to 10% over rated operating voltage (AC). Voltage tolerance is even greater in DC applications.

Universal voltage capability

All RZ7-FE timing relays operate with multiple supply voltages ranging from 24VAC or DC to 240VAC. Universal voltage capability means smaller inventories and more flexibility.

Choose from two different output contacts

The RZ7-FE series has a choice between one normally open (NO) contact or one single pole double throw (SPDT) contact. The SPDT version can be used either normally open or normally closed. This version has several technical advantages such as shorter impulse duration requirements and a faster recovery time.



Multiple functions in one relay

The RZ7-FEM relay combines four of the most popular timing functions into one device. Six timing ranges are included that are individually selectable from 0.05 seconds to 10 hours. This multifunction relay reduces inventories and is ideal for maintaining remote installations where stocking several different timing relays would not be practical.

Many safety and convenience features

- Each relay is equipped with an LED that indicates output status conditions.
- Finger and back of hand protection to IP40.
- Terminals are captive and supplied in the open position.
- All RZ7's can be surface mounted, rail mounted, or mounted directly on our family of CA7/CS7 devices.
- RZ7 relays can be mounted in any plane.
- Terminals, setting knob and LED's are all accessible from the front of the unit.
- RZ7-FE Timing Relays are very compact, measuring approximately 1" x 3" x 3".

Quick Selection Guide

Single Function Timing Relays				
RZ7-FE	A	1	T	U22
Type	Function	Contacts	Time Ranges	Supply Voltages
	A On-Delay B Off-Delay D One Shot / Watchdog E Fleeting Off-Delay ❷ F Symmetric flasher starting with a pulse L Impulse Converter ❷	Functions A, B, D & F 1 One normally open contact	T 0.05s...10 hours ❶	U22 24VAC or DC 110...240V 50/60Hz A1/A2
		All Functions: 3 One single pole double contact	T 0.05s...10 hours ❶	U23 24...48VDC 24...240V 50/60Hz A1/A2

Multi-Function Timing Relays				
RZ7-FE	M	1	T	U22
Type	Function	Contacts	Time Ranges	Supply Voltages
	M Multi-function Four single functions - On-delay - Off-delay - One shot - Symmetric flasher starting with a pulse	1 One normally open contact	T 0.05s...10 hours ❶	U22 24VAC or DC 110...240V 50/60Hz A1/A2
		3 One single pole double contact	T 0.05s...10 hours ❶	U23 24...48VDC 24...240V 50/60Hz A1/A2

Special Function Timing Relays				
RZ7-FE	Y	2	Q	U23
Type	Function	Contacts	Time Ranges	Supply Voltages
	Y Wye-Delta Timing Relay	2 Two normally open contacts (one side common)	Q 0.15s...10 minutes ❶	U23 24...48VDC 24...240V 50/60Hz A1/A2 A1/A2

Illustration for reference only. See selection tables for specific catalog numbers.

❶ Multi-time setting range. See appropriate catalog page for specific time settings.
 ❷ Not available in RZ7-FEx1 model.

RZ7-FE Timing Relays – Single Function, One Pole

Functional Description	Functional Diagram	Terminal Arrangement	Type	Catalog Number
ON-Delay Timing Relay (A) When supply voltage is applied, output contact(s) change state after time delay <i>t</i> .			<ul style="list-style-type: none"> • One NO contact • Multi-timing range (from 0.05s to 10h) Ⓜ • Supply voltage selected via wiring terminals A1, A2 • Bicolored LED indicator 	RZ7-FEA1TU22
			<ul style="list-style-type: none"> • One SPDT contact • Multi-timing range (from 0.05s to 10h) Ⓜ • "Universal" terminals accept all appropriate supply voltages • Bicolored LED indicator 	RZ7-FEA3TU23
OFF-Delay Timing Relay (B) When control contact B1 closes, the output contact changes state immediately. When control contact B1 opens, the output contact changes state after time delay <i>t</i> . Constant supply voltage required on terminals A1/A2 or A3/A2.			<ul style="list-style-type: none"> • One NO contact • Multi-timing range (from 0.05s to 10h) Ⓜ • Supply voltage selected via wiring terminals A1, A2 • Bicolored LED indicator 	RZ7-FEB1TU22
			<ul style="list-style-type: none"> • One SPDT contact • Multi-timing range (from 0.05s to 10h) Ⓜ • "Universal" terminals accept all appropriate supply voltages • Bicolored LED indicator 	RZ7-FEB3TU23
One Shot Relay / Watchdog (D) When supply voltage is applied, the output contact changes state for time period <i>t</i> .			<ul style="list-style-type: none"> • One NO contact • Multi-timing range (from 0.05s to 10h) Ⓜ • Supply voltage selected via wiring terminals A1, A2 • Bicolored LED indicator 	RZ7-FED1TU22
			<ul style="list-style-type: none"> • One SPDT contact • Multi-timing range (from 0.05s to 10h) Ⓜ • "Universal" terminals accept all appropriate supply voltages • Bicolored LED indicator 	RZ7-FED3TU23

Note: Control pulse duration minimum 250ms for RZ7-FEB1SU22; 50ms (AC) and 30ms (DC) for RZ7-FEB3TU23.

RZ7 Timing Relays

Supply Voltage

The last three digits in the catalog number represent the supply voltage range the relay will accept:

- U22** 24V AC or DC (A1/A2)
- 110...240V 50/60Hz (A1/A2)
- U23** 24...48VDC and 24...240V 50/60Hz (A1/A2)

Timing Range Codes

RZ7-FE
0.05...1 sec
0.5...10 sec
0.05...1 min
0.5...10 min
0.05...1 hour
0.5...10 hour

Bicolored LED

1 SPDT or 1 N.O. Contact Timers

- LED U = Green: Supply voltage available
- LED Relay = Red: Output is energized
- OFF: No color



RZ7-FE timing relay

Ⓜ For timing control, a voltage other than the supply voltage can also be used.
 Ⓜ Timing range is screwdriver selectable from the faceplate.

RZ7-FE Timing Relays – Single Function, One Pole

Functional Description	Functional Diagram	Terminal Arrangement	Type	Catalog Number
Symmetric Flasher Starting With A Pulse (F) When supply voltage is applied, the output contact changes state immediately and then repeatedly changes after every time period t , continuing until supply voltage is removed.			<ul style="list-style-type: none"> • One NO contact • Multi-timing range (from 0.05s to 10h) ② • Supply voltage selected via wiring terminals A1, A2 • Bicolored LED indicator 	RZ7-FEF1TU22
			<ul style="list-style-type: none"> • One SPDT contact • Multi-timing range (from 0.05s to 10h) ② • "Universal" terminals accept all appropriate supply voltages • Bicolored LED indicator 	RZ7-FEF3TU23
Fleeting OFF-Delay Timing Relay (E) When control contact B1 is pulsed, the output contact changes state for time period t . <i>Note: Control pulse duration minimum 50ms (AC) - 30ms (DC).</i>			<ul style="list-style-type: none"> • One SPDT contact • Multi-timing range (from 0.05s to 10h) ② • "Universal" terminals accept all appropriate supply voltages • Bicolored LED indicator 	RZ7-FEE3TU23
Impulse Converter (L) When a pulse is applied to control contact B1, the output contact changes state immediately for time period t . Pulses received during timing period t have no further effect. <i>Note: The period t is not dependent on the length of the control pulse. Control pulse duration minimum 50ms (AC) - 30ms (DC).</i>			<ul style="list-style-type: none"> • One SPDT contact • Multi-timing range (from 0.05s to 10h) ② • "Universal" terminals accept all appropriate supply voltages • Bicolored LED indicator 	RZ7-FEL3TU23

G
RZ7 Timing Relays

RZ7-FE Timing Relays – Special Function, One Pole

Functional Description	Functional Diagram	Terminal Arrangement	Type	Catalog Number
Wye-Delta Timing Relay (Y) When supply voltage is applied, output contact Y closes for time period t . After time period t , plus a fixed time period t_u , (50-65ms) output contact Δ closes.			<ul style="list-style-type: none"> • Two single pole N.O. contacts (one side common) • Multi-timing range (from 0.15s to 10m) ② • "Universal" terminals accept all appropriate supply voltages • LED indicator 	RZ7-FEY2QU23

Supply Voltage

The last three digits in the catalog number represent the supply voltage range the relay will accept:

U22	24V AC or DC	(A1/A2)
	110...240V 50/60Hz	(A1/A2)
U23	24...48VDC and 24...240V 50/60Hz	(A1/A2)

Timing Range Codes

RZ7-FE with NO or SPDT contact	RZ7-FEY with two NO contacts
0.05...1 sec	0.15...3 sec
0.5...10 sec	0.5...10 sec
0.05...1 min	0.05...1 min
0.5...10 min	0.5...10 min
0.05...1 hour	
0.5...10 hour	

Bicolored LED

1 SPDT or 1 N.O. Contact Timers

- LED U = Green: Supply voltage available
- LED Relay = Red: Output is energized
- OFF: No color

Single Color LED

2 N.O. with Common

- ON = Green: Output is energized
- OFF = No Color

- ① For timing control, a voltage other than the supply voltage can also be used.
- ② Timing range is screwdriver selectable from the faceplate.

RZ7-FE Timing Relays – Multi-Function, One Pole

RZ7-FEM Multi-function Relay	Functional Description	Type	Catalog Number
	<p>Multi-Function Relay (M) The RZ7-FEM multifunction relay combines <i>four</i> timing functions in one device. Each timing function and timing range is selectable from the face of the relay with a screwdriver actuated knob. The RZ7-FEM offers the following timing functions:</p> <p>On-Delay Off-Delay One Shot/Watchdog Symmetric Flasher Starting With a Pulse</p> <p>The RZ7-FEM3 offers one single pole double throw contact that can be used as either a normally open or normally closed contact.</p>	<ul style="list-style-type: none"> • One NO contact • Multi-timing range (from 0.05s to 10h) ② • Supply voltage selected via wiring terminals A1, A2 • Bicolored LED indicator 	RZ7-FEM1TU22
		<ul style="list-style-type: none"> • One SPDT contact • Multi-timing range (from 0.05s to 10h) ② • "Universal" terminals accept all appropriate supply voltages • Bicolored LED indicator 	RZ7-FEM3TU23

(A) On-Delay

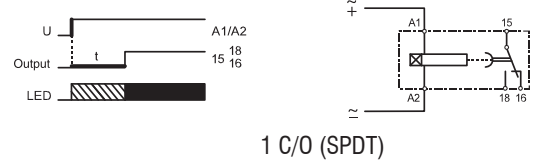
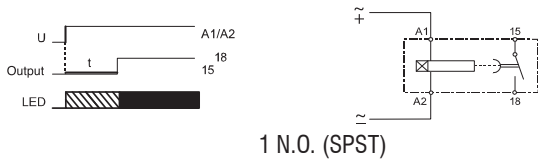

(D) One Shot

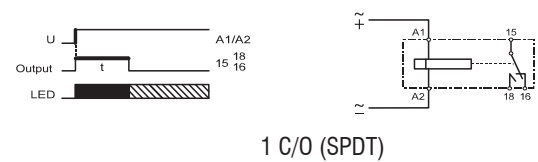
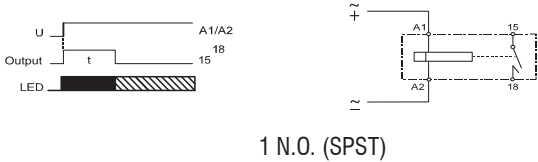

(B) Off-Delay

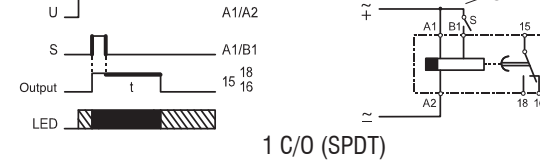
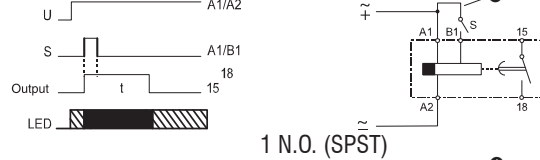

(F) Flasher (Repeat Cycle Starting with Pulse)

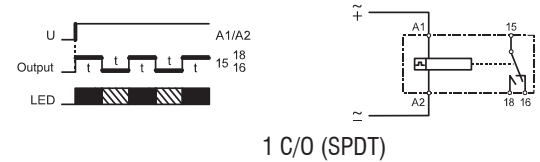
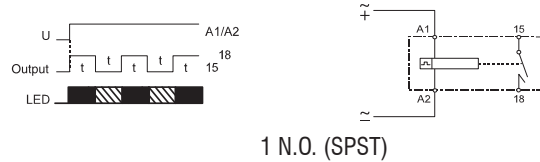

Supply Voltage

The last three digits in the catalog number represent the supply voltage range the relay will accept:



U22	24V AC or DC	(A1/A2)
	110...240V 50/60Hz	(A1/A2)
U23	24...48VDC and 24V...240V 50/60Hz	(A1/A2)

Timing Range Codes

RZ7-FEM with one NO or SPDT contact
0.05...1 sec
0.5...10 sec
0.05...1 min
0.5...10 min
0.05...1 hour
0.5...10 hour



Bicolored LED

1 SPDT or 1 N.O. Contact Timers



-  LED U = Green: Supply voltage available
-  LED Relay = Red: Output is energized
-  OFF: No color

- ① For timing control, a voltage other than the supply voltage can also be used.
- ② Timing range is screwdriver selectable from the faceplate.

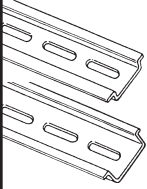
Accessories

Accessory	Description	Catalog Number
	Setting Knob With Scale - For time setting without tools.	RZ7-FSK
	Panel Mounting Adaptor - For surface mounting RZ7-FS/FE timing relays.	RZ7-FSA ②
	DIN-rail - 2 meter lengths (≈6' 6") Top Hat, low profile (price per rail) Top Hat, high profile (price per rail)	3F 3AF

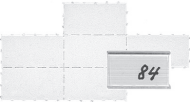
Marking Systems

Component	Description	Pkg. Qty.	Catalog Number
	Label Sheet - 1 sheet with 105 self-adhesive paper labels each, 6 x 17mm	1	CA7-FMS
	Marking Tag Sheet - 1 sheet with 160 perforated paper labels each, 6 x 17mm. To be used with transparent cover.	1	CA7-FMP
	Transparent Cover - To be used with Marking Tag Sheets.	100 ①	CA7-FMC
	Tag Carrier - For marking with Series V7 Clip-on Tags.	100 ①	CA7-FMA2

① Minimum order quantity is one package of 100.
② The RZ7 timing relay can be panel or DIN rail mounted. For best long-term performance, allow at least 5mm (0.2 in.) of space on each side of the relay for proper ventilation.

Technical Data

Timing Characteristics (according to VDE 0435, Part 2021)		
Timing ranges for		
RZ7-FSM-A, B, C, D, E, F, I, & L	(1s)	0.05...1 sec
RZ7-FSH	(3s)	0.15...3 sec
	(10s)	0.5...10 sec
	(1mn)	0.05...1 min
	(3mn)	0.15...3 min
	(10mn)	0.5...10 min
	(1h)	0.05...1 hour
	(3h)	0.15...3 hours
	(10h)	0.5...10 hours
	(60h)	3...60 hours
RZ7-FSQ	(2.5s)	0.15...2.5 sec
	(10s)	0.5...10 sec
	(80s)	4...80 sec
	(10mn)	0.5...10 min
Setting accuracy	±5% of full scale value	
Repeatability	±0.2% of the setting values	
Tolerance	Voltage: ±0.001%/ΔU Temperature: ±0.025%/°C	
Power Supply		
Supply voltages	24...48VDC and 24...240VAC, 50/60Hz (multi voltage) 12VDC 24...240V AC or DC (universal voltage) 346...440VAC, 50/60Hz	
Voltage tolerance	AC: -15%... +10% DC: -20%... +20%	
Power consumption	AC: 5VA at 240V DC: 0.5W at 24V	
Time energized	100%	
Reset time	50ms	
Voltage interruption	≤20ms without reset (supply voltage)	
Input impedance	Relay On: 3k-13k ohms Relay Off: 0.7k-4k ohms	
Cable length (supply voltage control)	250 meters (800 ft.) max.	
Pulse Control (B1)		
Impulse duration	≥50ms (AC), ≥30ms (DC)	
Input voltage	Supply voltage range	
Input current	1 mA	
Max. Leakage Current	400 micro Amps	
Cable length	max. 250 m (800 ft.) without parallel load between B1 & A2 max. 50 m (160 ft.) with load (<3kΩ) between B1 & A2	
Outputs		
Type of outputs	Relay contacts: hard silver	
Maximum admissible operating voltage	Alternating current: 440VAC	
Dielectric Coil to contact Withstand Voltage	5,000 V	
Switching capacity		
Current I_m : (AC1)	8A (5A for RZ7-FSQ)	
Power:	2000VA according to IEC947-5-1: 3A/440VAC (inductive load, AC14) 3A/250VAC (inductive load, AC15) 1A/24VDC (inductive load, DC13) according to UL 508: 1.5A/250VAC (B300) 3A/120VAC (B300)	

Short circuit resistance	10 A gL (fast blow fuse)
Life expectancy (electrical)	4 million ops. at 1A/250VAC, $\cos\phi = 1$ 0.2 million ops. at 6A/250VAC, $\cos\phi = 1$ 1.5 million ops. at 1A/250VAC, $\cos\phi = 0.3$ 0.3 million ops. at 3A/250VAC, $\cos\phi = 0.3$ 0.5 million ops. at 6A/24VDC, resistive 2 million ops. at 4A/24VDC, resistive 2 million ops. at 0.2A/230VDC, resistive 1 million ops. at 0.4A/24VDC, L/R = 20ms 1 million ops. at 0.2A/110VDC, L/R = 20ms 1 million ops. at 0.1A/230VDC, L/R = 20ms
Life expectancy (mechanical)	30 million operations
General Data	
Insulation Characteristics	2 kVAC/50 Hz test voltage according to VDE 0435 and 6 kV 1.2/50 μs surge voltage according to IEC 947-1 between all inputs and outputs
EMC/Interference Immunity	Performance of following requirements: - Surge capacity of the supply voltage according to IEC1000-4-5: 4 kV 1.2/50 μs - Burst according to IEC 1000-4-4: 6 kV/ 6/50ns - ESD discharge according to IEC 1000-4-2: - Contact 8 kV, air 8 kV - Electromagnetic HF field according to IEC 801-3 and conducted electromagnetic HF signal according to IEC 801-6: Level 3
EMC/Emission	Electromagnetic fields according to EN 55 022: Class B
Safe isolation	According to VDE 106, part 101
Climatic withstand	56 cycles (24h) at 25...40°C and 95% relative humidity according to IEC 68-2-30 and IEC 68-2-3.
Vibration resistance	4 g in 3 axis at 10...500 Hz, test FC according to IEC 68-2-6
Shock resistance	50 g according to IEC 68-2-27
Protection class	Enclosure: IP40 Terminal: IP30 (single function) IP20 according to IEC 947-1
Weight	100g
Approvals/Standards	UL File E14840, C-UL up to 240VAC, CE
Ambient temperature	Open: -25°C... +60°C Enclosed: -25°C... +45°C Storage: -40°C... +85°C
Connections	Screw terminal - M3.5 for Pozidrive No.2, Phillips and slotted screws No.2 suitable for power screwdriver. Rated tightening torque - 0.8 Nm (max. 1.2 Nm) - [8.8 lb-in] Wire Size - Dual-chamber system for terminal cross-sections of 1 x 0.5mm ² (solid) or 2 x 2.5mm ² (flexible with sleeve), AWG 20...14.
Finger Protection -	According to VDE 0106
Mounting	Can be panel or DIN rail mounted. For best performance allow at least 5mm (0.2in.) of space on each side for proper ventilation. - Snap-on mounting (35mm DIN-rail) - Side mounting on CA7contactors and CS7 with dovetail joint [surface mounting in any position] - Screw fixing by Panel Mount Adapter and two screws (M4) [surface mounting in any position]
Disposal	Synthetic material without dioxin according to EC/EFTA notification No. 93/0141/D. Electrical contacts contain cadmium.
Standards	EN 60947-1, EN 60947-5-1, EN 50081-1, IEC 947, UL 508, CSA 22.2 No. 14

RZ7 Relative Scale Setting Knob

Series RZ7 Timing Relays have a "relative scale" setting knob numbered 0 to 1.0. Think about this as 0 to 100% of the relay's built-in time range. Example: To set an RZ7-FS timing relay (with a 0.05 to 1 minute range) to activate after 25 seconds:



- 1) Divide the desired activation time (25 seconds) by the maximum time limit of the relay (60 seconds).

$$25 \div 60 = .416$$

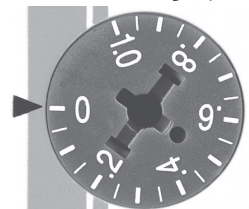
- 2) Rotate the setting knob to just past the .4 mark.



Technical Data

	RZ7-FE With NO Contact 	RZ7-FE With SPDT Contact 
Setting Accuracy	±5% of the time range final value (t_{max})	±5% of the time range final value (t_{max})
Repeatability	±1% of the time range final value (t_{max})	±1% of the time range final value (t_{max})
Tolerance	by voltage: ±0.01%/ΔU by temperature: ±0.25%/°C	by voltage: ±0.001%/ΔU by temperature: ±0.025%/°C
Supply		
Supply Voltage	24 AC or DC and 110...240VAC, 50/60Hz	24...48VDC and 24...240VAC, 50/60 Hz
Voltage Tolerance	-15%/+20% (DC), -15%/+10% (AC)	-15%/+20% (DC), -15%/+10% (AC)
Power Consumption	0.5W at 24VDC, 5VA at 240VAC	0.5W at 24VDC, 5VA at 240VAC
Timer Energized	100%	100%
Recovery Time	100ms	100ms
Voltage Isolation	-	≤30ms without reset (supply voltage)
Cable length (supply voltage control)	max. 250 meters (750 ft.)	max. 250 meters (750 ft.)
Pulse Control (B1)		
Impulse Duration	≥250ms	≥50ms (AC), ≥30ms (DC)
Input Voltage	supply voltage range	supply voltage range
Input Current	1mA	1mA
Cable Length	max. 250 meters without parallel load between B1 and A2 max. 50 meters with load (<3 kΩ) between B1 and A2	max. 250 meters without parallel load between B1 and A2 max. 50 meters with load (<3 kΩ) between B1 and A2
Outputs		
Contact Type	1N.O. contact	1 Form C-SPDT contact
Switching Capacity	Voltage: 250VAC	250VAC
	Current: 5A (Resistive, AC1)	5A (Resistive, AC1)
	Power: 1250VA	1250VA
	according to IEC 947-5-1:	1A/250VAC (inductive load, AC14) 1A/24VDC (inductive load, DC13)
according to UL508:	1A/300VAC (D300)	1A/300VAC (D300)
Short Circuit Resistance	6A gL (fast blow fuse)	6A gL (fast blow fuse)
Dielectric Withstand Voltage (contact to coil)	4000V	4000V
Life	mechanical:	20 million operations
	electrical operations:	0.4 Mil. at 1A/250VAC, $\cos\phi = 1$
		0.4 Mil. at 0.5A/250VAC, $\cos\phi = 0.4$
		0.4 Mil. at 1A/24VDC, resistive
State Indicator	1 bicolored LED (Supply = green; Relay = red)	
General Characteristics		
Insulation Characteristics	2 kVAC/50Hz test voltage according to VDE 0435 and 4kV 1.2/50μs surge voltage according to IEC 947-1 between all inputs and outputs	
EMC Interference Immunity	The following requirements are fulfilled: Surge capacity of the supply voltage according to IEC 1000-4-5: Level 3. Burst according to IEC 1000-4-4: Level 3. ESD discharge according to IEC 1000-4-2: Level 3.	
EMC/Emission	electromagnetic fields according to EN 55 022: Class B	
Safe Isolation	according to VDE 106, Part 101	
Climatic Withstand	56 cycles (24h) at 25...40°C and 95% relative humidity according to IEC 68-2-30 and IEC 68-2-3	
Vibration Resistance	4g in 3 axis at 10...500Hz, test FC according to IEC 68-2-6	
Shock Resistance	50g according to IEC 68-2-27	
Protection Class	Enclosure: IP40 Terminal: IP20	
Weight	60g	
Approvals/Standards	UL File E14840, C-UL, CE	
Ambient Temperature	Open: -25°C...+60°C	
	Enclosed: -25°C...+45°C	
	Storage: -40°C...+85°C	
Standard	EN 60947-1, EN 60947-5-1, EN 50081-1, IEC 947, UL 508, CSA 22.2	

Technical Data (continued)

	RZ7-FE With NO Contact	RZ7-FE With SPDT Contact
General Characteristics (continued)		
Connections	Screw terminals: Rated tightening torque: Wire size: Finger protection:	M3 for Pozidrive No: 1, Phillips and slotted screws No: 2, suitable for power screwdriver 0.8Nm (max. 1.0Nm) [8.8 lb-in] Cross-sections of 1 x 0.5mm ² ...2 x 1.5mm ² (solid) or 2 x 1.5mm ² (stranded with sleeve) AWG 20...14
Mounting	Can be panel or DIN rail mounted. For best performance allow at least 5mm (0.2in.) of space on each side for proper ventilation. - according to VDE 0106 - Snap-on mounting on 35mm DIN-rail - Side mounting on CA7 contactors and CS7 with dovetail joint [surface mounting in any position] - Screw fixing by Panel Mount and two screws (M4) - [surface mounting in any position]	
Disposal	Synthetic materials without dioxin according to EC/EFTA-Notification No: 93/0141/D Electrical contacts contain cadmium	

RZ7 Relative Scale Setting Knob

Series RZ7 Timing Relays have a “relative scale” setting knob numbered 0 to 1.0. Think about this as 0 to 100% of the relay’s built-in time range.

Example: To set an RZ7-FE timing relay (with a 0.05 to 1 minute range) to activate after 25 seconds:

- 1) Divide the desired activation time (25 seconds) by the maximum time limit of the relay (60 seconds).

$$25 \div 60 = .416$$

- 2) Rotate the setting knob to just past the .4 mark

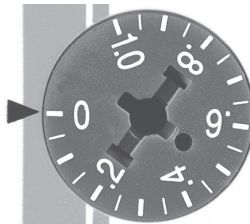

0.05 to 1 minute range)

Series RZ7-FS Timing Relays (one and two pole)

Dimensions are in millimeters (inches). Dimensions not intended for manufacturing purposes.

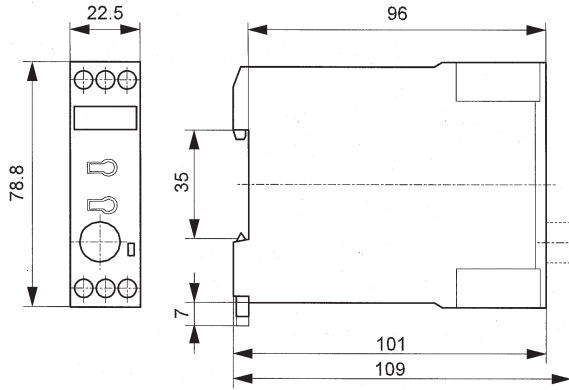

RZ7-FS (1 SPDT contact)

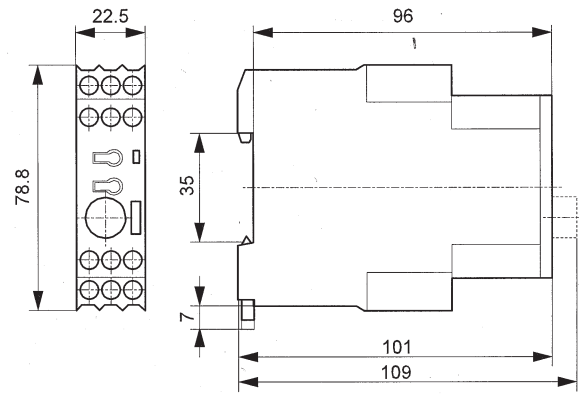

RZ7-FS (2 SPDT contacts)

Panel Mount Adaptor (RZ7-FSA)

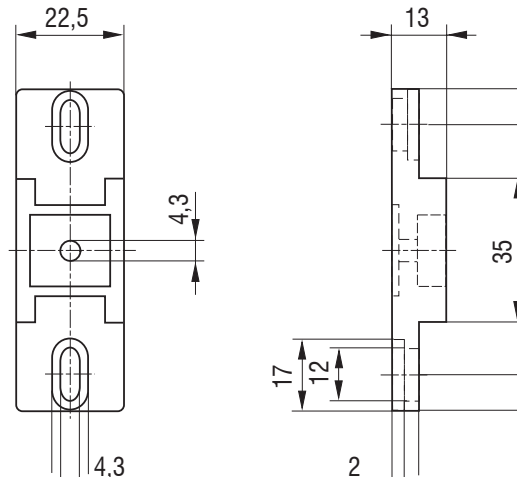

Series RZ7-FE Timing Relays (one and two pole)

Dimensions are in inches (millimeters). Dimensions not intended for manufacturing purposes.

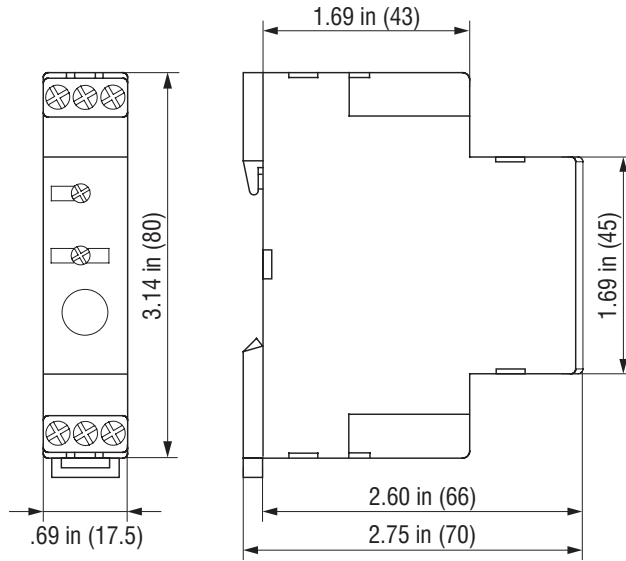

Panel Mount Adaptor (26.506.221-01)

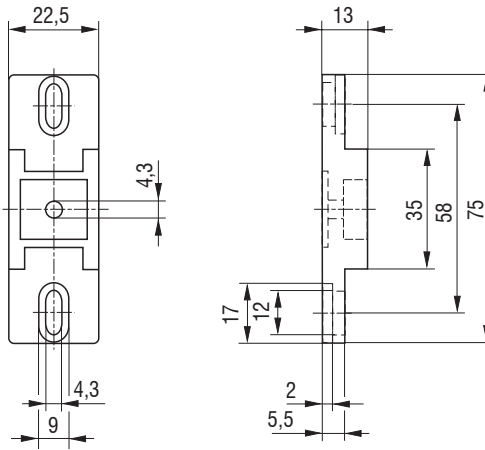

General Purpose Relays R2N/R4N Miniature Power Plug-in Relays

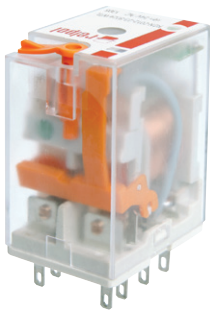

R2N Miniature Blade Type Relay

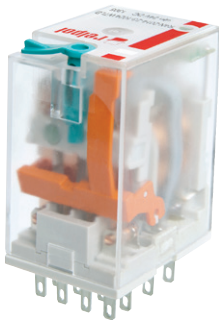

R4N Miniature Blade Type Relay



The Repol R2N and R4N General Purpose Miniature Power Relays, typically called “miniature cube type” in the industry, offer high reliability and ruggedness without sacrificing the convenience and economy users have come to expect from relays in this size class. This line of plug-in devices is well suited to any application where a dependable low cost control relay is required.

Versatile design for any application

The R2N miniature power relay is rated at 12 amps resistive @240VAC and is available in a 2PDT (2 form-C contacts) contact arrangement. The R4N relay is rated at 6 amps resistive @240VAC and available in a 4PDT (4 form-C contacts) contact design.

The relay contact materials are cadmium-free and are made of highly reliable silver nickel (AgNi) which can perform to currents as low as 5mA@5V. For lower level signal applications, the R4N is also available with silver nickel gold plated contacts for circuits 2mA.

Each relay style is available in ten coil voltages from 6V DC to 110V DC and 6V AC to 240V AC.

Extremely rugged and reliable

The R2N and R4N relays provides long lasting high quality contact reliability even after millions of operations, due to their hard silver contacts with a mechanical life of 20 million cycles, and high contact switching capacity.

Convenient features

All R Series miniature power relay features a mechanical “flag” and a one piece “push-to-test button/latching” lever. The “push-to-test” button permits a momentary testing of the relay contacts. The “latching” lever allows the relay contacts to remain closed for longer testing periods until released back to normal.

These standard features save time and labor when troubleshooting control circuitry.

A LED position indicator that shows whether the relay is energized and that the contacts have changed over is available as standard. All relays with DC coils are bi-polar, which means polarity input can either be +/- or -/+ to energize the coil.

DIN-rail mounted relay sockets

The GZT relay sockets offer a unique look in an IEC slim design style. The sockets can be DIN-mounted or screwed directly onto the panel. The socket terminals are fully opened and pin numbers are clearly identified. The relays are easily secured and fastened to the relay sockets. For high vibration applications, optional retainer clips are available to firmly hold the relays to the socket base.

Safety Approvals

The R2N and R4N are UL recognized, CSA certified, VDE certified and CE marked which meets the requirements of all important international approval organizations, making them ideal for use in both domestic and export equipment.

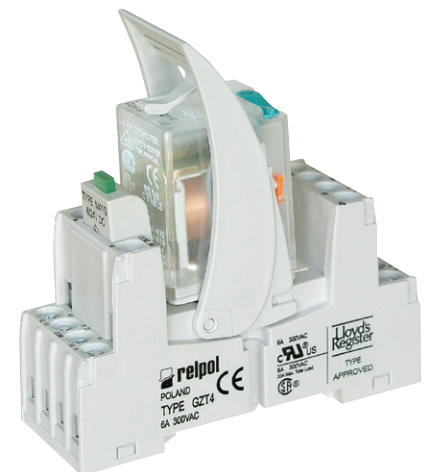

R4N relay and GZT4 socket with GZT4-0040 retainer clip

Interface PCB Relays PI84/PI85



RM84 Interface PCB Relay used in PI84 complete assembly



RM85 Interface PCB Relay used in PI85 complete assembly



The Relpol PI84/PI85 Interface PCB Relays offer a unique design for high current applications. The low current input and power consumption with load capabilities of high current switching is ideal for limited input sources and panel space savings.

A full featured model in one small package

The PI84/PI85 interface PCB relays are offered as a complete package which includes the following five factory installed pieces:

1. PCB (Printed Circuit Board module)
2. Relay socket
3. LED position indicator
4. Retainer clip
5. Description plate

Low input current, high switching capabilities

The PI84 interface PCB relays is rated at 8 amps resistive @250VAC and is available in a 2PDT (2 form-C contacts). The PI85 is rated at 16 amps resistive @250VAC and is available in a SPDT (1 form-C contact). The coil power consumption is approximately 750mA AC or 480mW DC.

Both interface relay styles are available in 24V DC, 24V AC and 120V AC models.

Rugged and reliable

With a mechanical life of 20 million cycles, and high contact switching capacity due to their hard nickel cadmium contacts, the PI84/PI85 interface PCB relays provide long lasting high quality contact reliability even after millions of operations.

DIN-rail mounted relay sockets

The PI84/PI85 interface relay DIN-mounted sockets offer a slim space savings design. The relay socket includes a retainer clip to firmly hold the PCB relay and a description plate as standard.

Safety Approvals

The RM84 & RM85 interface PCB relays are UL recognized, CSA, VDE certified and CE marked which meets the requirements of all important international approval organizations, making them ideal for use in both domestic and export equipment.

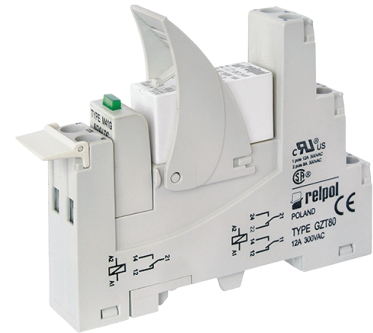

PI84 Interface PCB Relay complete assembly

Interface PCB Relays (Form C) - 2 Pole

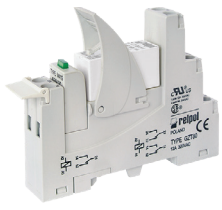
PI84 PCB Relay	Description	Position Indication	Coil Voltage	Discontinued	Catalog Number	Pkg Qty
	8A DPDT 2 Pole (2 Form C) AgNi Contacts Includes: PCB relay, plug-in socket, protective module, retainer clip and description plate	Electrical LED	24VDC	PI84-24DC-M41G	PI84-024DC-M41G-TS-2012	10
			24VAC	PI84-24AC-M91G	PI84-024AC-M91G-TS-2012	
			120VAC	PI84-120AC-M93G	PI84-120AC-M93G-TS-2012	

Interface PCB Relays (Form C) - 1 Pole

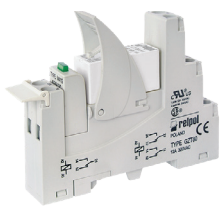
PI85 PCB Relay	Description	Position Indication	Coil Voltage	Discontinued	Catalog Number	Pkg Qty
	16A SPDT 1 Pole (1 Form C) AgNi Contacts Includes: PCB relay, plug-in socket, protective module, retainer clip and description plate	Electrical LED	24VDC	PI85-24DC-M41G	PI85-024DC-M41G-TS-2011	10
			24VAC	PI85-24AC-M91G	PI85-024AC-M91G-TS-2011	
			120VAC	PI85-120AC-M93G	PI85-120AC-M93G-TS-2011	

Accessories

RM84/RM85	Description	For use with...	Catalog Number	Pkg Qty
 RM85	Replacement PCB Relay Replacement operational relays for PI84/PI85 Interface PCB Relays	PI84-024DC-M41G	RM84-2012-25-1024	20
		PI84-024AC-M91G	RM84-2012-25-5024	
		PI84-120AC-M93G	RM84-2012-25-5120	
		PI85-024DC-M41G	RM85-2011-25-1024	20
		PI85-024AC-M91G	RM85-2011-25-5024	
		PI85-120AC-M93G	RM85-2011-25-5120	

R15 Plug-in Power Relays Tube Base Style

The Relpol R15 General Purpose Plug-in Power Relays offer high reliability and ruggedness in a full featured model design. This line of plug-in devices is well suited for the traditional tube base market. This is widely used in the industry where a dependable low cost control relay is required.

Designed for traditional applications

The R15 plug-in power relay is rated at 10 amps resistive @250VAC and is available in a 2PDT (2 form-C contacts) and 3PDT (3 form-C contacts) contact arrangement. The two pole and three pole relays are housed in traditional 8 pin and 11 pin designs.

The relay contact materials are cadmium-free and are made of highly reliable silver nickel (AgNi) which can perform to currents as low as 5mA@5V. The R15 relays are available in ten coil voltages from 6V DC to 110V DC and 6V AC to 240V AC.

Rugged and reliable

The R15 plug-in power relays provide long lasting high quality contact reliability even after millions of operations, due to their hard silver contacts with a mechanical life of 20 million cycles, and high contact switching capacity.

Convenient features

All R15 plug-in power relays feature a mechanical “flag” and a one piece “push-to-test button/latching” lever. The “push-to-test” button permits a momentary testing of the relay contacts. The “latching” lever allows the relay contacts to remain closed for longer testing periods until released back to normal. These standard features save time and labor when troubleshooting control circuitry.

A LED position indicator shows whether the relay is energized and the contacts have changed over is available as standard.

DIN-rail mounted relay sockets

The PZ relay sockets offer a unique look in an IEC slim design style. The sockets can be DIN-mounted or screwed directly onto the panel. The socket terminals are fully opened and pin numbers are clearly identified. The relays are easily secured and fastened to the relay sockets. For high vibration applications, optional retainer clips are available to firmly hold the relays to the socket base.

Safety Approvals

The R15 plug-in power relays are UL recognized, CSA certified, VDE certified and CE marked which meets the requirements of all important international approval organizations, making them ideal for use in both domestic and export equipment.



R15 2PDT 8-Pin Relay



R15 3PDT 11-Pin Relay

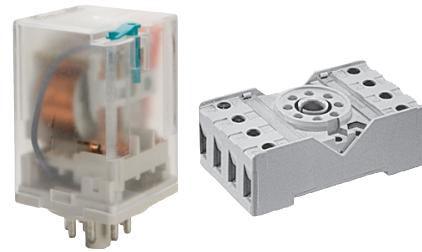

R15 2PDT relay and PZ8 socket

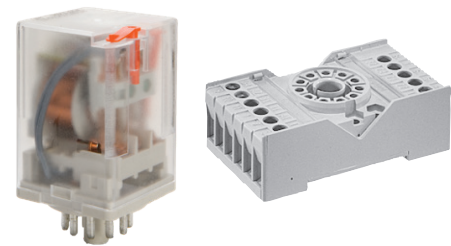

R15 3PDT relay and PZ11 socket



G

Relpol Control Relays

Plug-in Relays 2 Pole (Form C) - Tube Base 8-Pin Type ①

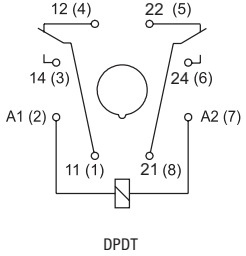
R15 Relay	Description	Position Indication	Diagram (pin side view)	Coil Voltage	Catalog Number	Pkg Qty
	10A DPDT 2 Pole (2 Form C) AgNi Contacts Features: Push-to-test/ Latching Lever as standard Built-in LED Bi-polar input for DC versions	Indicating Flag Electrical LED		6VDC	R15-2012-23-1006-WTL	10
				12VDC	R15-2012-23-1012-WTL	
				24VDC	R15-2012-23-1024-WTL	
				48VDC	R15-2012-23-1048-WTL	
				110VDC	R15-2012-23-1110-WTL	
				6VAC	R15-2012-23-5006-WTL	
				12VAC	R15-2012-23-5012-WTL	
				24VAC	R15-2012-23-5024-WTL	
				120VAC	R15-2012-23-5120-WTL	
				240VAC	R15-2012-23-5240-WTL	

Plug-in Relays 3 Pole (Form C) - Tube Base 11-Pin Type ①

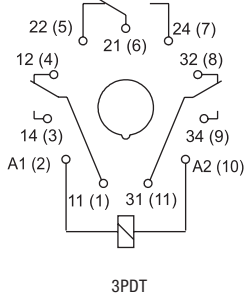

R15 Relay	Description	Position Indication	Diagram (pin side view)	Coil Voltage	Catalog Number	Pkg Qty
	10A 3PDT 3 Pole (3 Form C) AgNi Contacts Features: Push-to-test/ Latching Lever as standard Built-in LED Bi-polar input for DC versions	Indicating Flag Electrical LED		6VDC	R15-2013-23-1006-WTL	10
				12VDC	R15-2013-23-1012-WTL	
				24VDC	R15-2013-23-1024-WTL	
				48VDC	R15-2013-23-1048-WTL	
				110VDC	R15-2013-23-1110-WTL	
				6VAC	R15-2013-23-5006-WTL	
				12VAC	R15-2013-23-5012-WTL	
				24VAC	R15-2013-23-5024-WTL	
				120VAC	R15-2013-23-5120-WTL	
				240VAC	R15-2013-23-5240-WTL	

G

Relpol Control Relays

① The standard features of “Push-to-test/Latching” lever can be easily removed and plugged with an accessory plug or push-to-test button. See installation guide and accessory plugs/push-to-test buttons on page G49.

Accessories

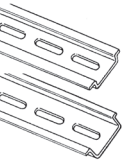
Accessory	Description	Catalog Number	Pkg Qty
	Screw Terminal, Relpol Tube Base 8-PIN Socket for R15 relays - Panel or DIN-rail mounting - 10A, 250V rating, UR, CSA	PZ8	10
	Screw Terminal, Relpol Tube Base 11-PIN Socket for R15 relays - Panel or DIN-rail mounting - 10A, 250V rating, UR, CSA	PZ11	10
	Retainer clip for PZ8 & PZ11 tube base relay sockets	PZ11-0031	25
	DIN-rail - 2 meter lengths (6' 6") Top Hat, low profile Top Hat, high profile	3F 3AF	20 12

Accessories

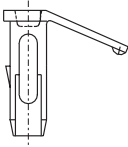
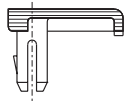
Accessory	Description	Catalog Number	Pkg Qty
	<p>P-Type button (push-to-test button) ❶</p> <p>See application details below.</p> <p>For R15 Relays with AC Coils (orange button)</p> <p>For R15 Relays with DC Coils (green button)</p>	<p>R15-M404-A</p> <p>R15-M404-D</p>	100
	<p>Relay hole plug. Plugs the hole when the T or P type inserts ❶ are removed. See installation details below.</p> <p>For R15 Relays with AC Coils (orange button)</p> <p>For R15 Relays with DC Coils (green button)</p>	<p>R15-M203-A</p> <p>R15-M203-D</p>	100

Plug & P-type button (Push-to-test) for R15 Relays

The R15 relays are equipped with a one-piece “T” insert that functions either as Push-to-test button or Latching of the relay contacts as standard. The “T” insert can be easily removed and replaced with an accessory Plug for applications that can not include these additional standard features.

The accessory P-Type button (Push-to-test) is recommended for applications that only require manual contact closure for control circuit testing. By manually pressing the P-Type button, the relay contacts change state for as long as the P-Type button is pressed. Contacts return to the initial position as soon as pressure is released from the P-Type button. This operation can be done while the coil is de-energized. The standard “T” insert can be easily removed and replaced with a P-Type button as shown.

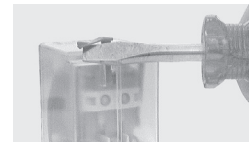

Remove the standard “T” plastic insert with a small screwdriver as shown

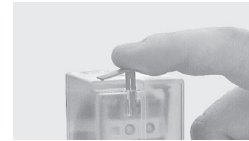

Insert the P-Type button or Plug as shown and snap down into place

❶ Minimum order quantity is one package of 100.

RUC Plug-in Power Relays Square Base Plug-in

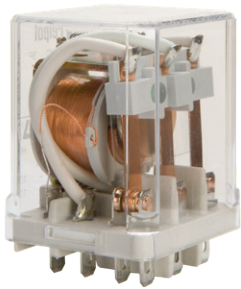

RUC 3PDT Blade Type relay



The Relpol RUC General Purpose Plug-in Power Relays offer high reliability and robustness in a traditional square base design. This line of plug-in devices is well suited for the traditional higher inrush current applications.

Designed for higher amps and inrush applications

The RUC plug-in power relay is rated at 15 amps resistive @250VAC and is available in a 2PDT (2 form-C contacts). It is also available in a 3PDT (3 form-C contacts) contact arrangement rated at 10 amps resistive @250VAC. These relays can handle inrush currents up to 40 amps.

The relay contact materials are made of highly reliable silver tin (AgSnO₂) which has a minimum switching capacity of 10mA @10V. The RUC relays are available in ten coil voltages from 6V DC to 110V DC and 6V AC to 240V AC.

Rugged and reliable

The RUC plug-in power relays provide long lasting high quality contact reliability even after millions of operations due to their hard nickel cadmium contacts, with a mechanical life of 20 million cycles, and high contact switching capacity.

Convenient features

The RUC plug-in power relay offers a LED position indicator that shows whether the relay is energized and that the contacts have changed over.

DIN-rail mounted relay sockets

The SB11 relay sockets offer a traditional look in an IEC design. The sockets can be DIN-mounted or screwed directly onto the panel. The terminal pin numbers are clearly identified. The relays are easily secured and fastened to the relay sockets. For high vibration applications, optional retainer clips are available to firmly hold the relays to the socket base.

Safety Approvals

The RUC plug-in power relays are UL recognized, CSA certified and CE marked which meets the requirements of all important international approval organizations, making them ideal for use in both domestic and export equipment.

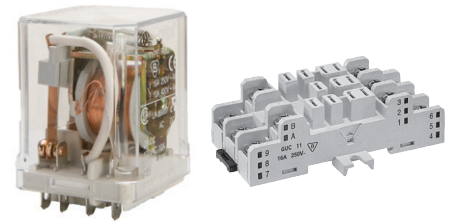

RUC 3PDT relay and SB11 socket

Plug-in Relays 2 Pole (Form C) - Square Base Blade Type ①

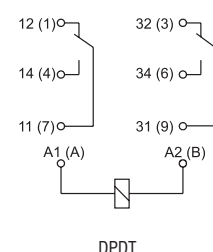

RUC Relay	Description	Position Indication	Diagram (pin side view)	Coil Voltage	Discontinued	Catalog Number	Pkg Qty
	15A DPDT 2 Pole (2 Form C) AgSnO ₂ Contacts Features: Built-in LED Bi-polar input for DC versions	Indicating Flag Electrical LED		6VDC	RUC-1012-26-1006-L	RUC-3012-26-1006-L	10
				12VDC	RUC-1012-26-1012-L	RUC-3012-26-1012-L	
				24VDC	RUC-1012-26-1024-L	RUC-3012-26-1024-L	
				48VDC	RUC-1012-26-1048-L	RUC-3012-26-1048-L	
				110VDC	RUC-1012-26-1110-L	RUC-3012-26-1110-L	
				6VAC	RUC-1012-26-5006-L	RUC-3012-26-5006-L	
				12VAC	RUC-1012-26-5012-L	RUC-3012-26-5012-L	
				24VAC	RUC-1012-26-5024-L	RUC-3012-26-5024-L	
				120VAC	RUC-1012-26-5120-L	RUC-3012-26-5120-L	
				240VAC	RUC-1012-26-5240-L	RUC-3012-26-5240-L	

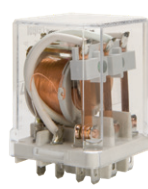
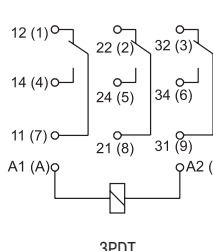
Plug-in Relays 3 Pole (Form C) - Square Base Blade Type ①

RUC Relay	Description	Position Indication	Diagram (pin side view)	Coil Voltage	Discontinued	Catalog Number	Pkg Qty
	10A 3PDT 3 Pole (3 Form C) AgSnO ₂ Contacts Features: Built-in LED Bi-polar input for DC versions	Indicating Flag Electrical LED		6VDC	RUC-1013-26-1006-L	RUC-3013-26-1006-L	10
				12VDC	RUC-1013-26-1012-L	RUC-3013-26-1012-L	
				24VDC	RUC-1013-26-1024-L	RUC-3013-26-1024-L	
				48VDC	RUC-1013-26-1048-L	RUC-3013-26-1048-L	
				110VDC	RUC-1013-26-1110-L	RUC-3013-26-1110-L	
				6VAC	RUC-1013-26-5006-L	RUC-3013-26-5006-L	
				12VAC	RUC-1013-26-5012-L	RUC-3013-26-5012-L	
				24VAC	RUC-1013-26-5024-L	RUC-3013-26-5024-L	
				120VAC	RUC-1013-26-5120-L	RUC-3013-26-5120-L	
				240VAC	RUC-1013-26-5240-L	RUC-3013-26-5240-L	

G
Relpol Control Relays

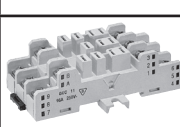
Accessories

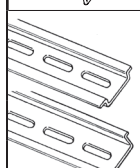
Accessory	Description	Catalog Number	Pkg Qty
	Screw Terminal, Square Base Blade type Socket for RUC relays - Panel or DIN-rail mounting ② - 15A, 300VAC rating, UR, CSA	SB11	10
	Retainer clip for SB11 tube base relay sockets	MBA	25
	DIN-rail - 2 meter lengths (6' 6") Top Hat, low profile Top Hat, high profile	3F 3AF	20 12

① Relays can be special ordered with No LED's, contact your Sprecher + Schuh representative.
 ② This product is sourced from a third party manufacturer, not Relpol.

RY2 Plug-in Power Relays Slim Square Base

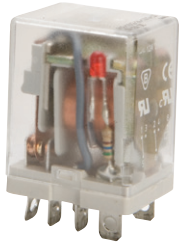

RY2 2PDT Blade Type Relay



The Relpol RY2 General Purpose Plug-in Power Relay is a traditional square base blade type style designed for higher current application in a small design.

Designed for higher amp applications in a reduced size

The RY2 plug-in power relay is rated at 12 amps resistive @250VAC and is available in a 2PDT (2 form-C contacts). These relays can handle inrush currents up to 20 amps in a small packaged design.

The relay contact materials are made of highly reliable silver nickel which has a minimum switching capacity of 5mA@5V. The RY2 relays are available in ten coil voltages from 6V DC to 110V DC and 6V AC to 240V AC.

Rugged and reliable

With a mechanical life of 20 million cycles, and high contact switching capacity due to their hard nickel cadmium contacts, the RY2 plug-in power relay provides long lasting high quality contact reliability even after millions of operations.

Convenient features

All RY2 plug-in power relays feature a mechanical “flag” indicator and a LED position indicator that shows whether the relay is energized and that the contacts have changed over.

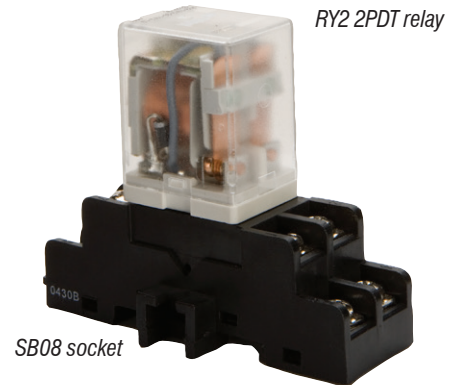

DIN-rail mounted relay sockets

The SB08 relay sockets offer a slim space savings design. The sockets can be DIN-mounted or screwed directly onto the panel. The terminal pin numbers are clearly identified. The relays are easily secured and fastened to the relay sockets. For high vibration applications, optional retainer clips are available to firmly hold the relays to the socket base.



Safety Approvals

The RY2 plug-in power relays are cURus recognized and CE marked which meets the requirements of all important international approval organizations, making them ideal for use in both domestic and export equipment.

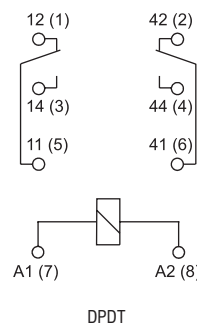
Plug-in Relays 2 Pole (Form C) - Slim Blade Type

RY2 Relay	Description	Position Indication	Diagram (pin side view)	Coil Voltage	Catalog Number	Pkg Qty
	12A DPDT 2 Pole (2 Form C) AgNi Contact Features: Built-in LED Bi-polar input for DC versions	Indicating Flag Electrical LED		6VDC	RY2-2012-26-1006-L	10
				12VDC	RY2-2012-26-1012-L	
				24VDC	RY2-2012-26-1024-L	
				48VDC	RY2-2012-26-1048-L	
				110VDC	RY2-2012-26-1110-L	
				6VAC	RY2-2012-26-5006-L	
				12VAC	RY2-2012-26-5012-L	
				24VAC	RY2-2012-26-5024-L	
				120VAC	RY2-2012-26-5120-L	
				240VAC	RY2-2012-26-5240-L	

Accessories

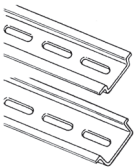
Accessory	Description	Catalog Number	Pkg Qty
	Screw Terminal, Square Base Blade type Socket for RY2 relays - Panel or DIN-rail mounting ① - 15A, 300VAC rating, UR, CSA	SB08	10
	Retainer clip for GZY2 tube base relay sockets	SP-8	25
	DIN-rail - 2 meter lengths (6' 6") Top Hat, low profile Top Hat, high profile	3F 3AF	20 12

① This product is sourced from a third party manufacturer, not Relpol.

Interface PCB Relays PI84/PI85



RM84 Interface PCB Relay used in PI84 complete assembly



RM85 Interface PCB Relay used in PI85 complete assembly



The Relpol PI84/PI85 Interface PCB Relays offer a unique design for high current applications. The low current input and power consumption with load capabilities of high current switching is ideal for limited input sources and panel space savings.

A full featured model in one small package

The PI84/PI85 interface PCB relays are offered as a complete package which includes the following five factory installed pieces:

1. PCB (Printed Circuit Board module)
2. Relay socket
3. LED position indicator
4. Retainer clip
5. Description plate

Low input current, high switching capabilities

The PI84 interface PCB relays is rated at 8 amps resistive @250VAC and is available in a 2PDT (2 form-C contacts). The PI85 is rated at 16 amps resistive @250VAC and is available in a SPDT (1 form-C contact). The coil power consumption is approximately 750mA AC or 480mW DC.

Both interface relay styles are available in 24V DC, 24V AC and 120V AC models.

Rugged and reliable

With a mechanical life of 20 million cycles, and high contact switching capacity due to their hard nickel cadmium contacts, the PI84/PI85 interface PCB relays provide long lasting high quality contact reliability even

after millions of operations.

DIN-rail mounted relay sockets

The PI84/PI85 interface relay DIN-mounted sockets offer a slim space savings design. The relay socket includes a retainer clip to firmly hold the PCB relay and a description plate as standard.

Safety Approvals

The RM84 & RM85 interface PCB relays are UL recognized, CSA, VDE certified and CE marked which meets the requirements of all important international approval organizations, making them ideal for use in both domestic and export equipment.

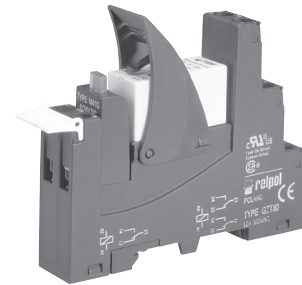

PI84 Interface PCB Relay complete assembly

Interface PCB Relays (Form C) - 2 Pole

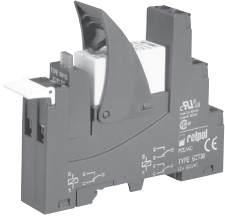
PI84 PCB Relay	Description	Position Indication	Coil Voltage	Catalog Number	Pkg Qty
	8A DPDT 2 Pole (2 Form C) AgNi Contacts Includes: PCB relay, plug-in socket, protective module, retainer clip and description plate	Electrical LED	24VDC	PI84-24DC-M41G	10
			24VAC	PI84-24AC-M91G	
			120VAC	PI84-120AC-M93G	

Interface PCB Relays (Form C) - 1 Pole

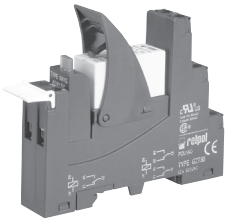
PI85 PCB Relay	Description	Position Indication	Coil Voltage	Catalog Number	Pkg Qty
	16A SPDT 1 Pole (1 Form C) AgNi Contacts Includes: PCB relay, plug-in socket, protective module, retainer clip and description plate	Electrical LED	24VDC	PI85-24DC-M41G	10
			24VAC	PI85-24AC-M91G	
			120VAC	PI85-120AC-M93G	

Accessories

RM84/RM85	Description	For use with...	Catalog Number	Pkg Qty
 RM85	Replacement PCB Relay Replacement operational relays for PI84/PI85 Interface PCB Relays	PI84-24DC-M41G	RM84-2012-25-1024	20
		PI84-24AC-M91G	RM84-2012-25-5024	
		PI84-120AC-M93G	RM84-2012-25-5120	
		PI85-24DC-M41G	RM85-2011-25-1024	20
		PI85-24AC-M91G	RM85-2011-25-5024	
		PI85-120AC-M93G	RM85-2011-25-5120	

PIR6W Slim Interface Terminal Block Relays

The Relpol PIR6W Slim Interface Terminal Block Relay is ideally compact, designed for a variety of high-density isolation and interposing applications.

A full featured model in one small package

The PIR6W slim interface relays are offered as a complete package which includes the following:

- Changeover relay, rated load 6 A / 230 V (ACI)
- Interface Relay socket with built-in LED position indicator
- Description plate

Low input current, high switching capabilities

The PIR6W slim interface relay contacts are rated at 6 amps resistive @230VAC and available in SPDT (1 form - C contact). The minimum contact current capabilities are 100mA at 24V. The coil power consumption is approximately 0.3...0.8VA AC or 0.3...0.9W DC. The PIR6W interface relays are available in 24V DC, 24V AC/DC and 120V models.



PIR6W Slim Interface Relay
Complete Assembly

Rugged and reliable

With a mechanical life of 20 million cycles, and high contact switching capacity due to their silver tin oxide (AgSnO₂) contacts, the PIR6W interface relays provide long lasting high quality contact reliability even after millions of operations.

DIN-rail mounted

The PIR6W slim interface relays are DIN-rail mountable which can be easily installed along side other control terminal blocks for a space saving design.

Safety approvals

The PIR6W slim interface relays are cURus, VDE and CE marked which meets the requirements of all important international approval organizations, making them ideal for use in both domestic and export equipment.

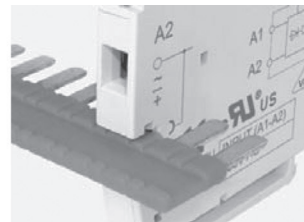

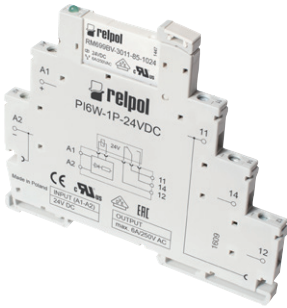
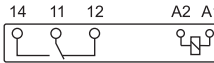

Interface Terminal Block Relays (1 Form C) - 1 Pole ①

PIR6W	Specifications	Input Voltage	Catalog Number	Pkg Qty
	 <p>6A SPDT 1 Pole (1 Form C) AgSnO₂</p> <p>Includes: – Change over relay with built-in Green LED indicator</p>	12VDC	PIR6W-1P-12VDC	10
		24VDC	PIR6W-1P-24VDC	
		24V AC/DC	PIR6W-1P-24VAC/DC	
		115V AC/DC	PIR6W-1P-115VAC/DC	

* Gray denotes special order.

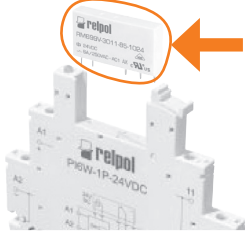
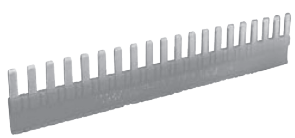
Accessories

Accessory	Description	For use with...	Catalog Number	Pkg Qty
	<p>Interface Operational Relay ② Replacement operational relays for PIR6W Interface Terminal Block Relays</p>	PIR6W-1P-12VDC	RM699BV-3011-85-1012	20
		PIR6W-1P-24VDC PIR6W-1P-24VAC/DC ③ PIR6W-1P-115VAC/DC	RM699BV-3011-85-1024	
	<p>20-Way Jumper Can be cut to required length 36A max per 20-way Jumper</p> <p>Red Black Blue</p>	PIR6W-1P...	<p>ZG20-1 ZG20-2 ZG20-3</p>	20
	<p>Replacement Description Plates Allows user to label individual PIR6W Relays (one included with PIR6W-1P Relays)</p>	PIR6W-1P...	P16W-1246	100

- ① Other input voltages available as special order; contact your Sprecher + Schuh Representative.
- ② It should be noted that rated voltage Un of the input/operational relay coil does not always comply with the rated voltage Un of the interface relay (which is important on ordering operational relays for sockets).
- ③ Previously accepted older model RM699V-3011-85-1012 12VDC replacement relay. Now supports a 24VDC relay model RM699BV-3011-85-1024.
- ④ In March 2016, Repol changed the DIN-rail fixing place location as represented in this view.

G
Repol Control Relays

Technical Information

		R2N	R4N
Contacts			
Contact number & arrangement		DPDT	4PDT
Contact material		AgNi	AgNi, AgNi/Au 5 μm
Max. switching voltage	AC/DC	250 V / 250 V	250 V / 250 V
Min. switching voltage		5 V	5 V
Rated load	AC1	12 A / 250 V AC	6 A / 250 V AC
	AC15	3 A / 120 V	1.5 A / 120 V
		1.5 A / 240 V (B300)	0.75 A / 240 V (C300)
	AC3	370 W (Single-phase motor)	125 W (Single-phase motor)
	DC1	12 A / 24 V DC	6 A / 24 V DC
	DC13	0.22 A / 120 V DC	0.22 A / 120 V DC
Min. switching current		5 mA AgNi	2 mA AgNi/Au 5 μm
Max. inrush current		24 A	12 A
Rated current		12 A	6 A
Max. breaking capacity	AC1	3 000 VA	1 500 VA
Min. breaking capacity		0,3 W AgNi	0,3 W AgNi, 0,1 W AgNi/Au 5 μm
Resistance		≤ 100 mΩ	
Max. operating frequency			
• at rated load	AC1	1 200 cycles/hour	
• no load		18 000 cycles/hour	
General data			
Operating time (typical value)			
Release time (typical value)		AC: 10 ms DC: 13 ms	
Electrical life		AC: 8 ms DC: 3 ms	
• resistive AC1		≥ 10 ⁵ 12 A, 250 V AC	≥ 10 ⁵ 6 A, 250 V AC
• cos φ		see graphs on page G67	
Mechanical life (cycles)		≥ 2 x 10 ⁷	
Dimensions (L x W x H)		27,5 x 21,2 x 35,6 mm	
Weight		35 g	
Ambient temperature			
• storing		-40...+85 °C	
• operating		AC: -40...+55 °C DC: -40...+70 °C	
Cover protection category		IP 40	
Shock resistance	(NO/NC)	10 g / 5 g	
Vibration resistance		5 g 10...150 Hz	
Solder bath temperature		max. 270 °C	
Soldering time		max. 5 s	
Insulation			
Insulation category		C250	B250
Insulation rated voltage		250 V AC	
Dielectric strength			
• coil - contact		2 500 V AC	
• contact - contact		1 500 V AC	
• pole - pole		2,500 V AC	2,000 V AC
Contact - coil distance			
• clearance		≥ 2,5 mm	≥ 1,6 mm
• creepage		≥ 4 mm	≥ 3,2 mm
UL/CSA Ratings			
Contact Ratings, General Purpose		10A 250V AC 12A 150V AC	6A 250VAC
DC Rating		10A 28V DC	
UL File Number		E105728	
CSA File Number		LR86957	
Standards		UL 508, CAN/CSA-C22.2 No. 14	

Technical Information

		R2N	R4N
Coil			
Rated voltage	50/60 Hz AC		6...240 V
Contact material	DC		6...110 V
Must release voltage		AC: $\geq 0,2 U_n$ DC: $\geq 0,1 U_n$	
Operating range of supply voltage		see tables below	
Rated power consumption	AC		1,6 VA
	DC		0,9 W

Coil Data - AC 50/60 Hz voltage version

Coil Code	Rated Voltage V AC	Coil Resistance ($\pm 10\%$) at 20 °C	Coil Operating Range V AC	
			min. (at 20 °C)	max. (at 55 °C)
5006	6	9,8	4,8	6,6
5012	12	39,5	9,6	13,2
2024	24	158,0	19,2	26,4
5120	120	3 770,0	96,0	132,0
5240	240	16 800,0	192,0	264,0

Coil Data - DC voltage version

Coil Code	Rated Voltage V DC	Coil Resistance ($\pm 10\%$) at 20 °C	Coil Operating Range V DC	
			min. (at 20 °C)	max. (at 55 °C)
1006	6	40	4,8	6,6
1012	12	160	9,6	13,2
1024	24	640	19,2	26,4
1048	48	2600	38,4	52,8
1110	110	13 600	88,0	121,0

R2N Connections Diagram

(pin side view)

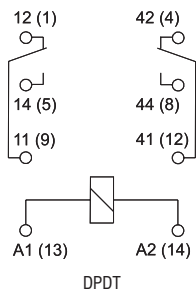
R4N-2014 Connections Diagram

(pin side view)

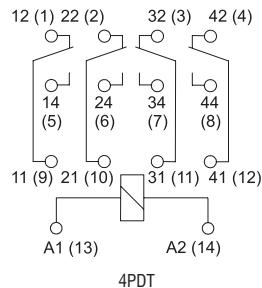
R4N-2314 Connections Diagram

(pin side view)

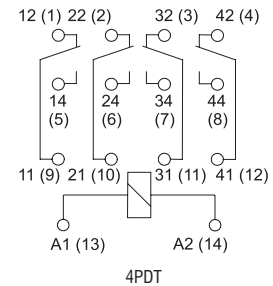

Note: Bi-polar input for DC versions

R2N

R4N

Electrical life at AC resistive load

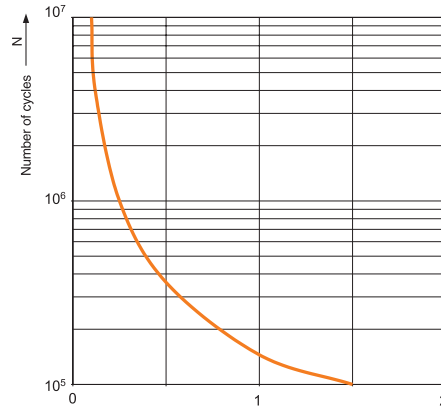
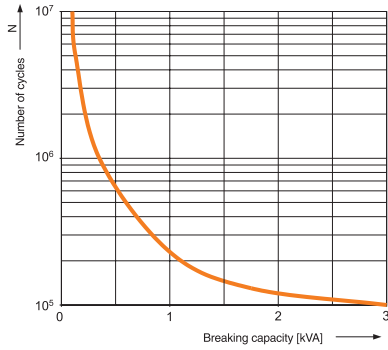
Electrical life at AC resistive load



Electrical life reduction factor at AC inductive load

Electrical life reduction factor at AC inductive load

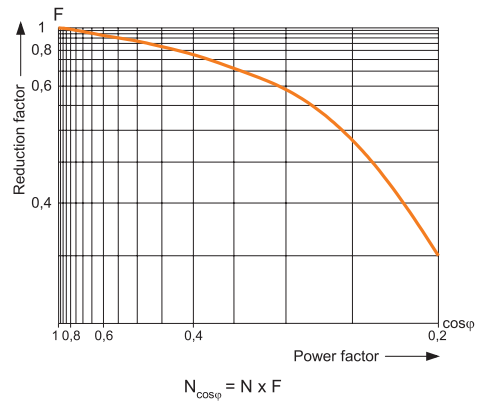
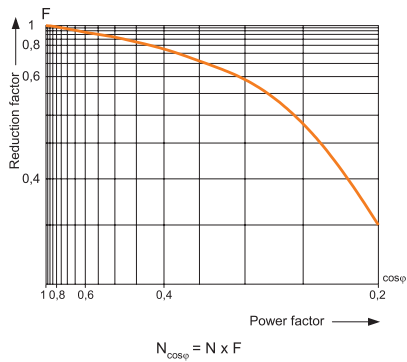

Maximum DC resistive load breaking capacity

Maximum DC resistive load breaking capacity

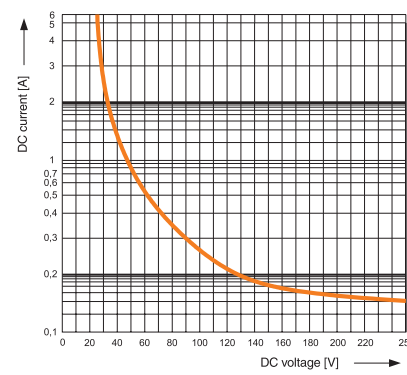
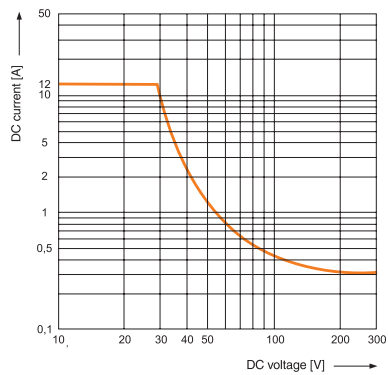

Dimensions are in millimeters (inches). Dimensions not intended for manufacturing purposes.

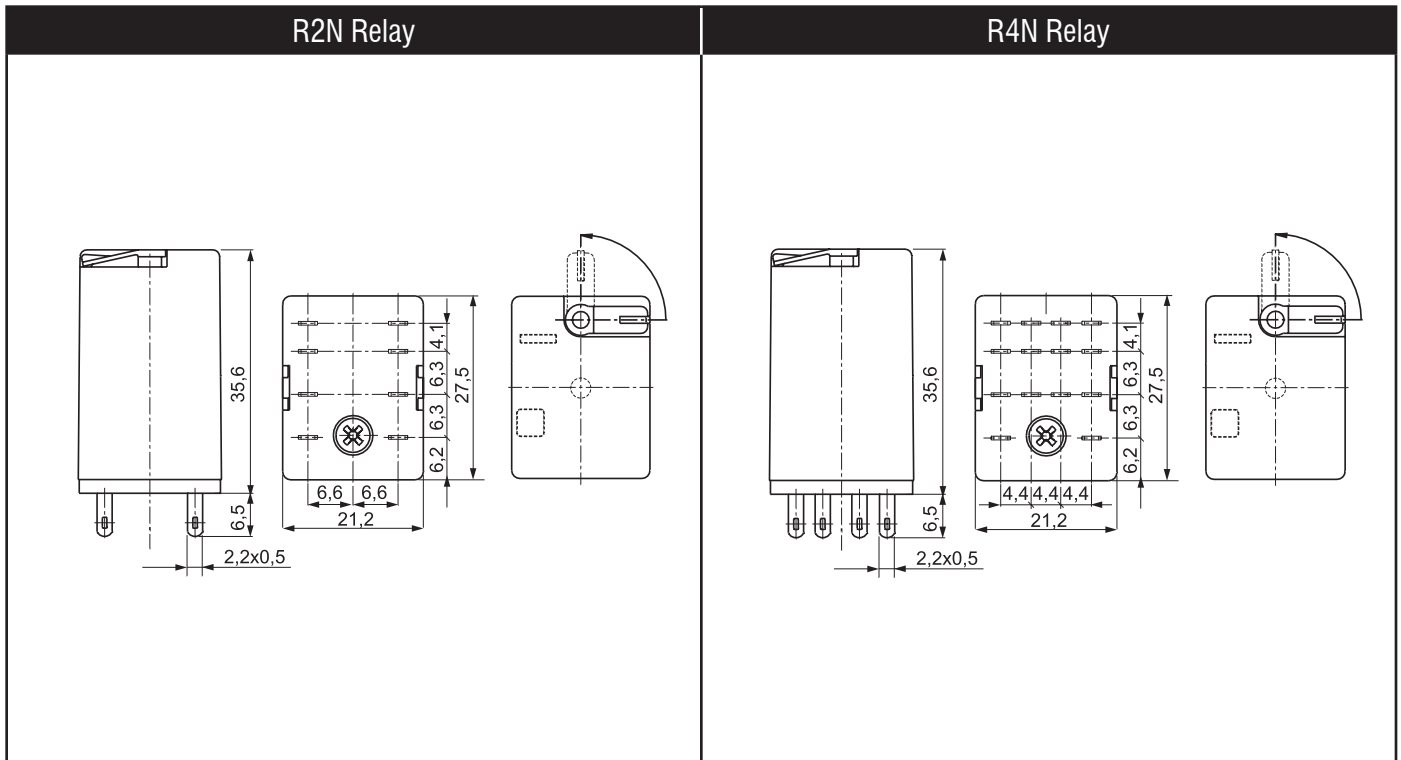

Retainer/Retractor Clip GZT4-0040S

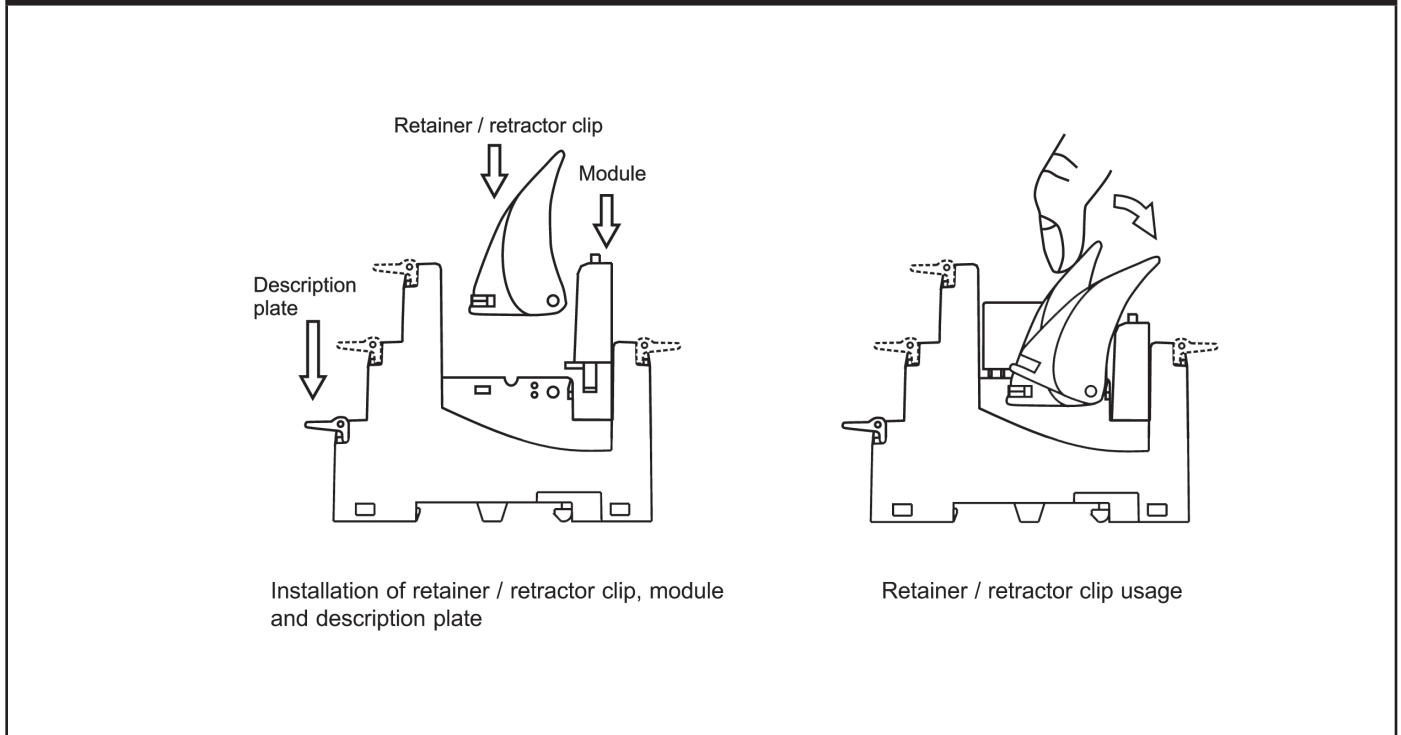

Dimensions are in millimeters (inches). Dimensions not intended for manufacturing purposes.

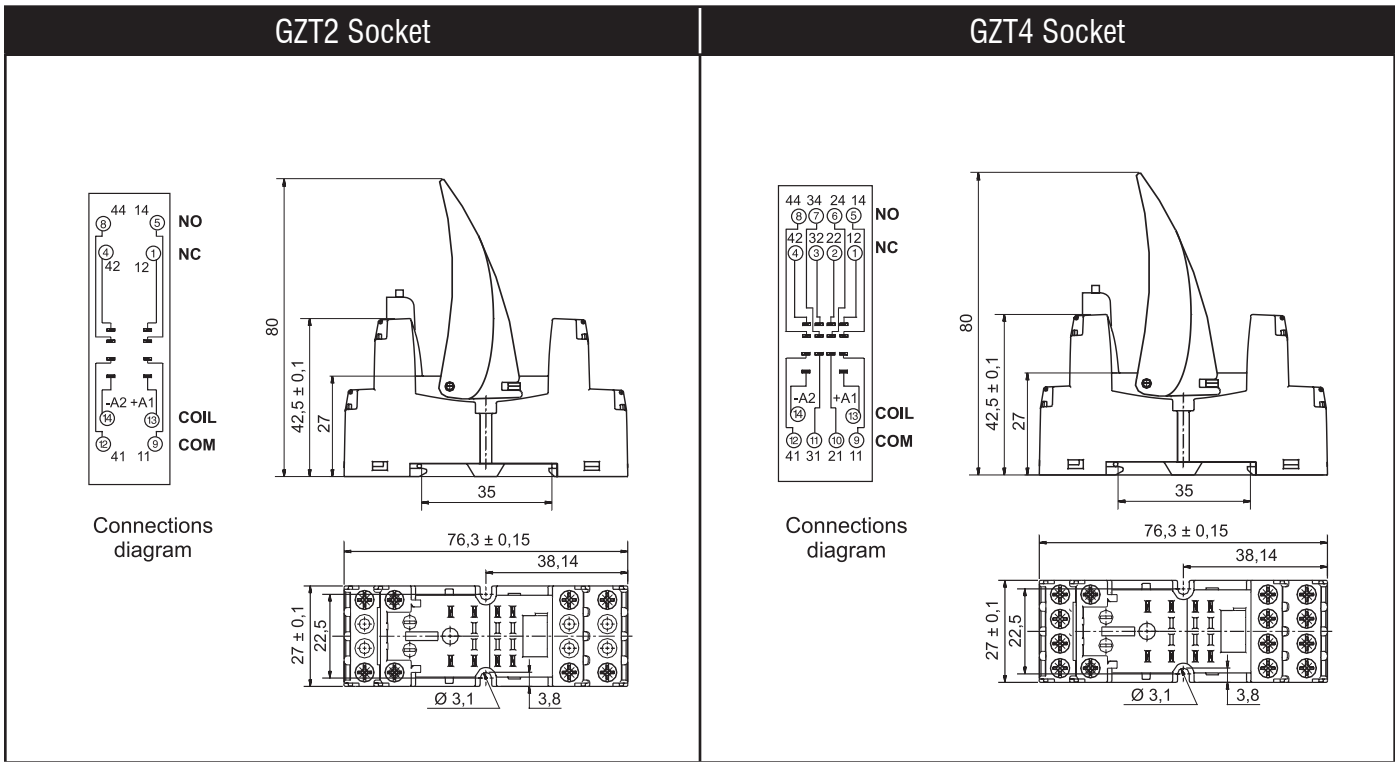

Technical Information
R15

Contacts				
Contact number & arrangement		DPDT, 3PDT		
Contact material		AgNi		
Max. switching voltage	AC/DC	250 V		
Min. switching voltage		5 V AgNi		
Rated load	AC1	10 A / 250 V AC		
	AC15	3 A / 120V	1.5 A / 240 V (B300)	
	AC3	370 W (single-phase motor 1/2 HP / 240 V AC UL 508)		
	DC1	10 A / 24 V DC		
	DC13	0.22 A / 250 V	0.1 A / 250 V (R300)	
Min. switching current		5 mA AgNi		
Max. inrush current		20 A		
Rated current		10 A		
Max. breaking capacity	AC1	2 500 VA		
Min. breaking capacity		0,3 W		
Resistance		≤ 100 mΩ		
Max. operating frequency				
• at rated load	AC1	1 200 cycles/hour		
• no load		12 000 cycles/hour		
General data				
Operating time (typical value)		AC: 12 ms DC: 18 ms		
Release time (typical value)		AC: 10 ms DC: 7 ms		
Electrical life				
• resistive AC1		≥ 2x10 ⁵ 10 A, 250 V AC		
• cosφ		see graphs on page G76		
Mechanical life (cycles)		≥ 2 x 10 ⁷		
Dimensions (L x W x H)		35 x 35x 54,4 mm		
Weight		83 g		
Ambient temperature				
• storing		-40...+85 °C		
• operating		AC: -40...+55 °C DC: -40...+70 °C		
Cover protection category		IP 40		
Shock resistance	(NO/NC)	10 g		
Vibration resistance		5 g 10...150 Hz		
Solder bath temperature		max. 270 °C		
Soldering time		max. 5 s		
Insulation				
Insulation category		C250		
Insulation rated voltage		250 V AC		
Dielectric strength				
• coil - contact		2 500 V AC		
• contact - contact		1 500 V AC		
• pole - pole		2 000 V AC		
Contact - coil distance				
• clearance		≥ 3 mm		
• creepage		4,2 mm		
UL/CSA Ratings				
Contact Ratings, General Purpose		10A - 120 250V AC, 240 VAC		
Pilot Duty Ratings		B300		
Contacts	Inductive	Make	Break	HP
	120VAC	30A	3A	1/3
	240VAC	15A	1.5A	1/2
	DC		10A 28V DC	
UL File Number		E105728		
CSA File Number		LR86957		
Standards		UL 508, CAN/CSA-C22.2 No. 14		

Technical Information
R15

Coil	
Rated voltage	AC: 6...240 V 50/60 Hz DC: 6...110 V
Must release voltage	AC: $\geq 0,15 U_n$ DC: $\geq 0,1 U_n$
Operating range of supply voltage	see coil data tables below
Rated power consumption	AC: 2,8 VA 50 Hz 2,5 VA 60 Hz DC: 1,5 W

Coil Data - AC 50/60 Hz voltage version

Coil Code	Rated Voltage V AC	Coil Resistance ($\pm 10\%$) at 20 °C Ω	Coil Operating Range V AC	
			min. (at 20 °C)	max. (at 55 °C)
5006	6	4,3	4,8	6,6
5012	12	18,5	9,6	13,2
2024	24	75,0	19,2	26,4
5120	120	1 910,0	96,0	132,0
5240	240	7 760,0	192,0	264,0

Coil Data - DC voltage version

Coil Code	Rated Voltage V DC	Coil Resistance ($\pm 10\%$) at 20 °C Ω	Coil Operating Range V DC	
			min. (at 20 °C)	max. (at 55 °C)
1006	6	28	4,8	6,6
1012	12	110	9,6	13,2
1024	24	430	19,2	26,4
1048	48	1 750	38,4	52,8
1110	110	9 200	88,0	121,0

R15 8-Pin Connection Diagram

(pin side view)

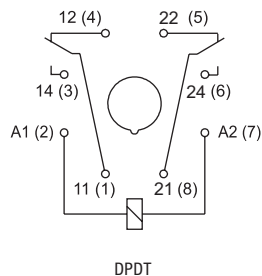
R15 11-Pin Connection Diagram

(pin side view)

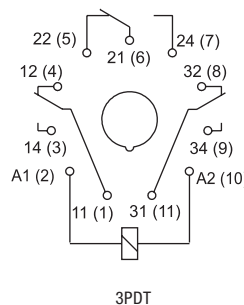

Note:
 Bi-polar input for
 DC versions

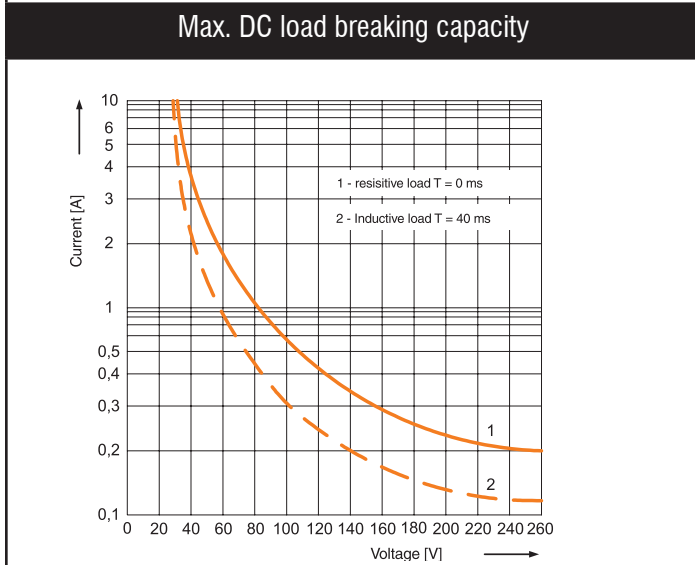
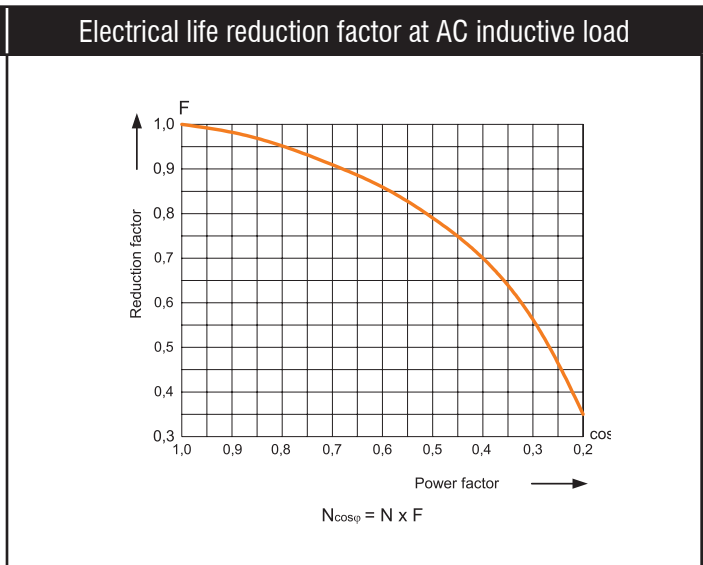
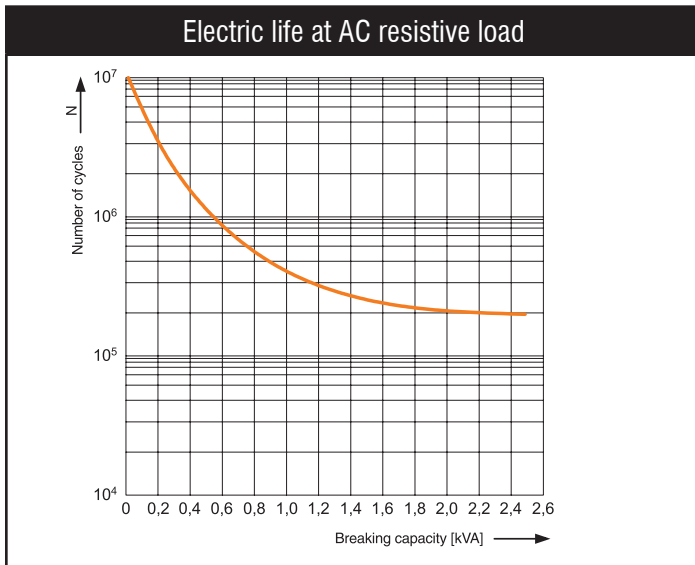

Dimensions are in millimeters (inches). Dimensions not intended for manufacturing purposes.

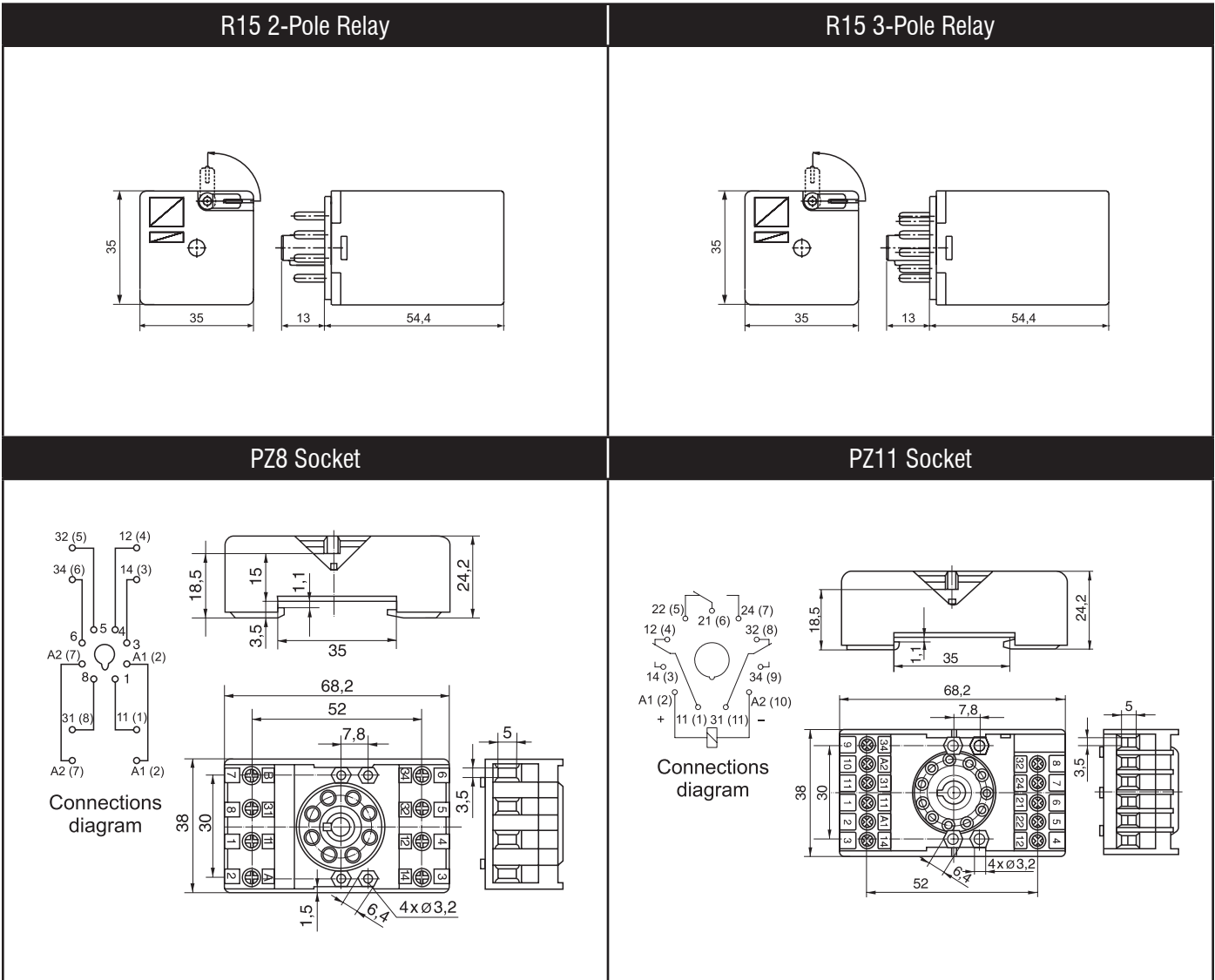

Technical Information

		RUC
Contacts		
Contact number & arrangement		DPDT, 3PDT
Contact material		AgSnO ₂
Max. switching voltage	AC/DC	250 V
Min. switching voltage		10 V
Rated load	AC1	16 A / 250 V AC
	DC1	16 A / 24 V DC
Min. switching current		10 mA
Max. inrush current		40 A
Rated current		16 A
Max. breaking capacity	AC1	4 000 VA
Min. breaking capacity		1 W
Resistance		≤ 100 mΩ
Max. operating frequency		
• at rated load	AC1	1 200 cycles/hour
• no load		12 000 cycles/hour
General data		
Operating time (typical value)		AC: 12 ms DC: 12 ms
Release time (typical value)		AC: 10 ms DC: 7 ms
Electrical life		
• resistive AC1		≥ 10 ⁵ 16 A, 250 V AC
• cos φ		see graphs on page <?>
Mechanical life (cycles)		≥ 10 ⁷
Dimensions (L x W x H)		38,6 x 36,1 x 45,5 mm
Weight		85 g
Ambient temperature		
• storage		-40...+85 °C
• operating	AC	-40...+55 °C 3 C/O, 3 NO / 16A (+70 °C 2 C/O, 2 NO / 16A)
	DC	-40...+55 °C 3 C/O, 3 NO / 16A (+70 °C 3 C/O, 3 NO / 10 A; 2 C/O, 2 NO / 16 A)
Cover protection category		IP 40
Shock resistance (NO/NC)		10 g
Vibration resistance		5 g 10...150 Hz
Solder bath temperature		max. 270 °C
Soldering time		max. 5 s

		RUC
Insulation		
Insulation category		C250
Insulation rated voltage		400 V AC
Dielectric strength		
• coil - contact		2 500 V AC
• contact - contact		1 500 V AC
• contact - contact 3 mm		2 500 V AC
• pole - pole		2 000 V AC
Contact - coil distance		
• clearance / • creepage		≥ 6 mm / ≥ 8 mm
UL/CSA Ratings		
Contact Ratings		DPDT 10A 250 V AC 3PDT 10A 250 V AC
General Purpose Rating		15A 250V (resistive) 10 A 250 V AC 15A 150 V AC
Motor Load according to UL 508		2 C/O: 1/3 HP 120 V AC single-phase motor 1/2 HP 240 V AC single-phase motor 3 C/O: 1/3 HP 120 V AC single-phase 1/2 HP 240 V AC single-phase motor 1/2 HP 240 V AC three-phase motor
Pilot Duty Ratings		B300
Contacts	Inductive	Make Break HP
	120VAC	30A 3A 1/3
	240VAC	15A 1.5A 1/2
	DC	10A 28V DC
UL File Number		E105728
CSA File Number		LR86957
Standards		UL 508, CAN/CSA-C22.2 No. 14
Coil		
Rated voltage	50/60 HzAC	6...240 V
	DC	6...110 V
Must release voltage		AC: ≥ 0,15 U _n DC: 0,1 U _n
Operating range of supply voltage		see coil data tables below
Rated power	AC	2,8 VA 50 Hz 2,5 VA 60 Hz
consumption	DC	1,5 W / 1,7 W with contact gap ≥ 3 mm

Coil Data - AC 50/60 Hz voltage version

Coil Code	Rated Voltage V AC	Coil Resistance (±10%) at 20 °C Ω	Coil Operating Range V AC	
			min. (at 20 °C)	max. (at 55 °C)
5006	6	4,3	4,8	6,6
5012	12	18,5	9,6	13,2
2024	24	75,0	19,2	26,4
5120	120	1 910	96,0	132,0
5240	240	7 760	192,0	264,0

Coil Data - DC voltage version

Coil Code	Rated Voltage V DC	Coil Resistance (±10%) at 20 °C Ω	Coil Operating Range V DC	
			min. (at 20 °C)	max. (at 55 °C)
1006	6	28	4,8	6,6
1012	12	110	9,6	13,2
1024	24	430	19,2	26,4
1048	48	1 750	38,4	52,8
1110	110	9 200	88,0	121,0

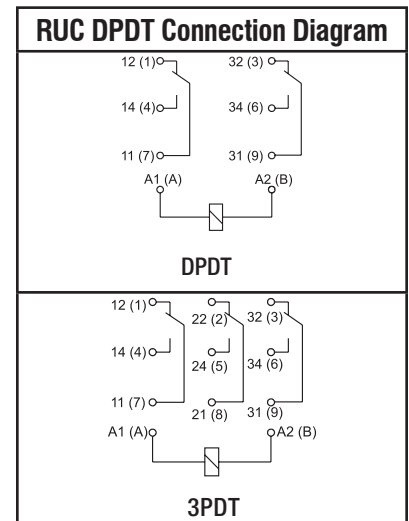

Dimensions are in millimeters (inches). Dimensions not intended for manufacturing purposes.

Electric life at AC resistive load

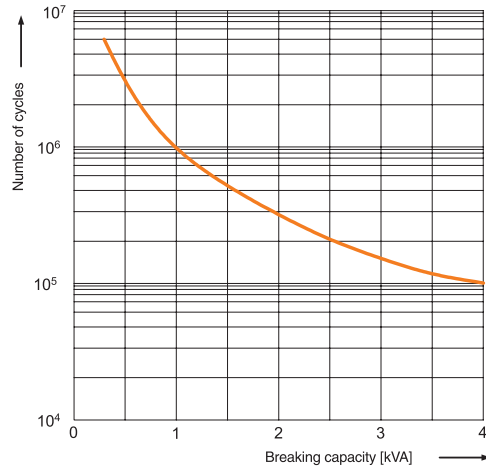

Electrical life reduction factor at AC inductive load

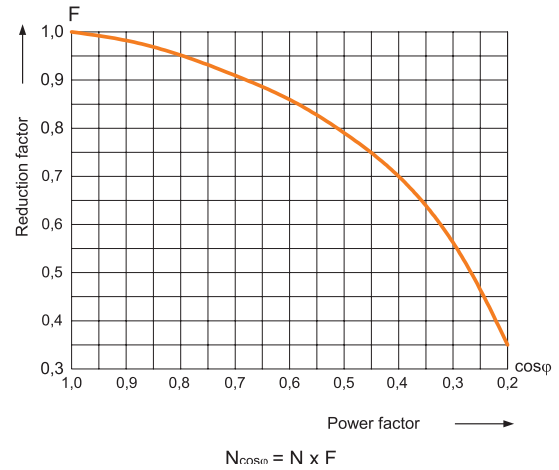

Max. DC load breaking capacity

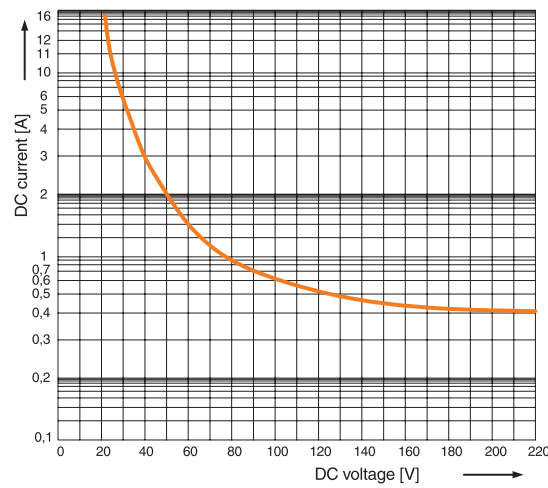

RUC Relay

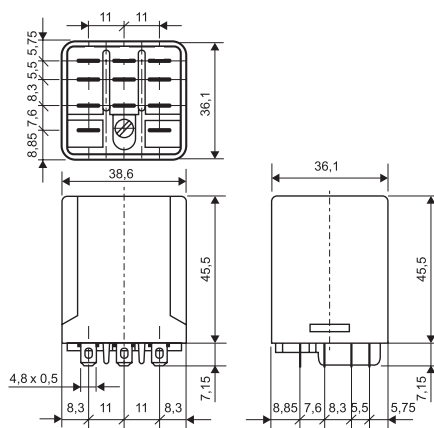

SB11 Socket

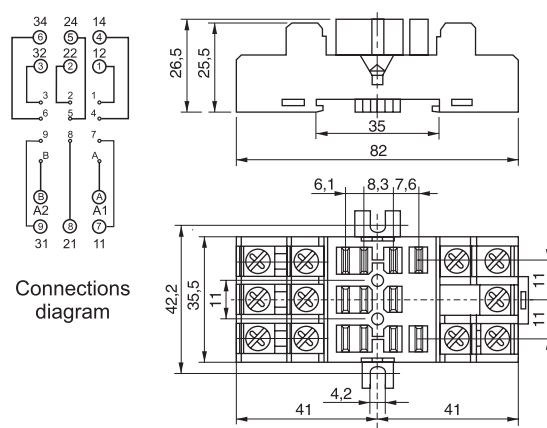

Technical Information

		RY2	
Contacts			
Contact number & arrangement		DPDT	
Contact material		RY2-1012 AgCdO / RY2-2012 AgNi	
Max. switching voltage	AC/DC	250 V / 250 V	
Min. switching voltage		AgCdO 10 V / AgNi 5 V	
Rated load	AC1	12 A / 250 V AC	
	DC1	12 A / 30 V DC	
Min. switching current		AgCdO 10 mA / AgNi 5 mA	
Max. inrush current		20 A	
Rated current		12 A	
Max. breaking capacity	AC1	3 000 VA	
Min. breaking capacity		1 W	
Resistance		≤ 100 mΩ	
Max. operating frequency		1 200 cycles/hour	
• at rated load	AC1	18 000 cycles/hour	
• no load			
General data			
Operating time (typical value)		15 ms	
Release time (typical value)		10 ms	
Electrical life			
• resistive AC1		≥ 10 ⁵ 12 A, 250 V AC	
• cos φ		see graphs on page G88	
Mechanical life (cycles)		≥ 10 ⁷	
Dimensions (L x W x H)		27,5 x 21,1 x 34,5 mm	
Weight		35 g	
Ambient temperature			
• storing		-40...+70 °C	
• operating		-40...+55 °C	
Cover protection category		IP 40	
Shock resistance	(NO/NC)	10 g	
Vibration resistance		5 g 15...150 Hz	
Solder bath temperature		max. 270 °C	
Soldering time		max. 5 s	
Insulation			
Insulation category		B250	
Insulation rated voltage		250 V AC	
Dielectric strength			
• coil - contact		2 500 V AC	
• contact - contact		1 500 V AC	
• pole - pole		2 500 V AC	
Contact - coil distance			
• clearance		≥ 2,6 mm	
• creepage		4 mm	
UL/CSA Ratings			
Contact Ratings			
General Purpose Rating		10A 250V AC	
Pilot Duty Ratings		B300	
Contacts	Inductive	Make	Break
	120VAC	30A	3A
	240VAC	15A	1.5A
	DC	10A 28V DC	
UL File Number		E105728	
Standards		UL 508	

Technical Information
RY2

Coil		
Rated voltage	50/60 Hz AC DC	6...240 V 6...110 V
Must release voltage		AC: $\geq 0,2 U_n$ DC: $0,1 U_n$
Operating range of supply voltage		see coil data tables below
Rated power consumption	AC DC	1,6 VA 0,9 W

Coil Data - AC 50/60 Hz voltage version

Coil Code	Rated Voltage V AC	Coil Resistance ($\pm 10\%$) at 20 °C Ω	Coil Operating Range V AC	
			min. (at 20 °C)	max. (at 55 °C)
5006	6	9,8	4,8	6,6
5012	12	39,5	9,6	13,2
2024	24	158,0	19,2	26,4
5120	120	3 770,0	96,0	132,0
5240	240	16 800,0	192,0	264,0

Coil Data - DC voltage version

Coil Code	Rated Voltage V DC	Coil Resistance ($\pm 10\%$) at 20 °C Ω	Coil Operating Range V DC	
			min. (at 20 °C)	max. (at 55 °C)
1006	6	40	4,0	5,5
1012	12	160	9,6	13,2
1024	24	640	19,2	26,4
1048	48	2 600	38,4	52,8
1110	110	13 600	88,0	121,0

RY2 Connection Diagram

(pin side view)

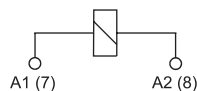
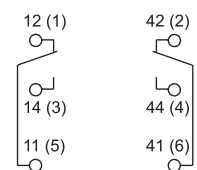

DPDT

Note: Bi-polar input for DC versions

Electric life at AC resistive load

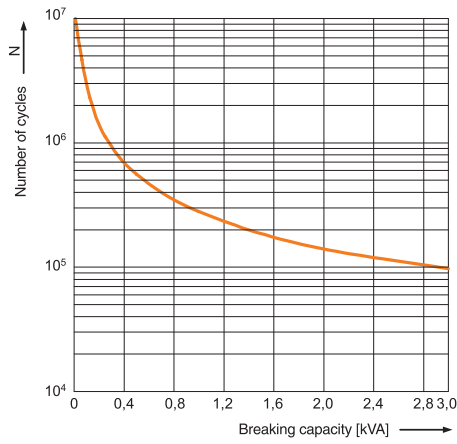

Electrical life reduction factor at AC inductive load

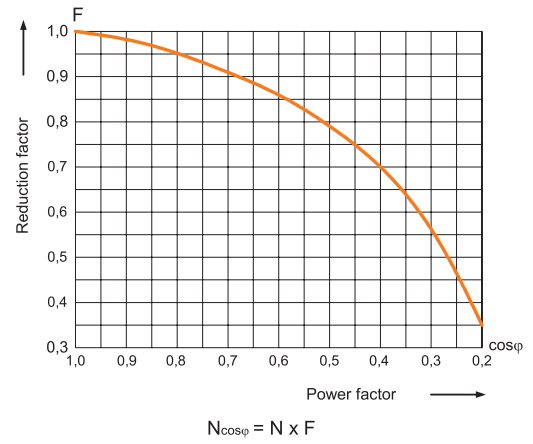

Dimensions

Dimensions are in millimeters (inches). Dimensions not intended for manufacturing purposes.

RY2 Relay

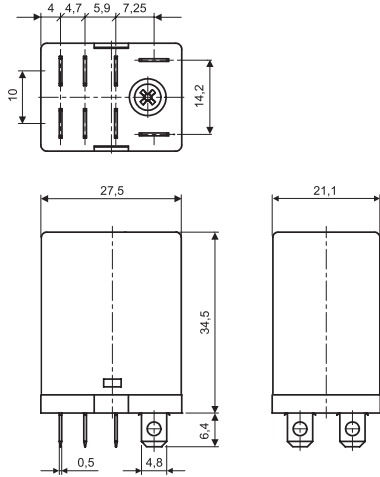

SB08 Socket

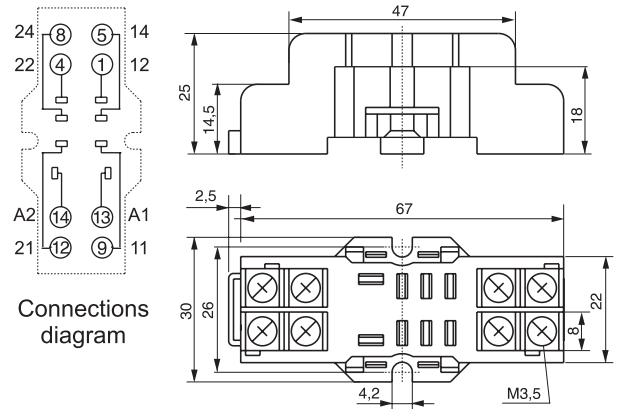

Technical Information

		PI84	PI85
Contacts			
Contact number & arrangement		DPDT	SPDT
Contact material		AgNi	
Max. switching voltage	AC/DC	400 V / 300 V	
Min. switching voltage		5 V	
Rated load	AC1 AC15	8 A / 250 V AC 3 A / 120 V AC	16 A / 250 V AC 3 A / 120 V AC
	AC3	1.5 A / 240 V AC (B300)	1.5 A / 240 V AC (B300)
	DC1	550 W (single-phase motor) 8 A / 24 V DC	750 W (single-phase motor) 16 A / 24 V DC
	DC13	0.22 A / 120 V DC 0.1 A / 250 V DC (R300)	0.22 A / 120 V DC 0.1 A / 250 V DC (R300)
Min. switching current		5 mA	
Max. inrush current		15 A	30 A
Rated current		8 A	16 A
Max. breaking capacity	AC1	2 000 VA	4 000 VA
Min. breaking capacity		0,3 W	
Resistance		≤ 100 mΩ	
Max. operating frequency			
• at rated load	AC1	600 cycles/hour	
• no load		172 000 cycles/hour	
General data			
Operating time (typical value)		7 ms	
Release time (typical value)		3 ms	
Electrical life			
• resistive AC1		> 10 ⁵ 8 A, 250 V AC	≥ 0.7 x 10 ⁵ 16 A, 250 V AC
• cos φ		see graphs on page 94	
Mechanical life (cycles)		≥ 3 x 10 ⁷	
Dimensions (L x W x H)		75,3 x 15,5 x 67 mm	
Weight		62 g	
Ambient temperature			
• storing		-40...+85 °C	
• operating		AC: -40...+70 °C DC: -40...+85 °C	
Protection category			
• cover		IP 40	
• terminals		IP 20	
Shock resistance		20 g	30 g
Vibration resistance	(NO/NC)	10 g / 5 g	
Insulation			
Insulation category		C250	
Insulation rated voltage		400 V AC	
Dielectric strength			
• coil - contact		5 000 V AC	
• contact - contact		1 000 V AC	
• pole - pole		2 500 V AC	
Contact - coil distance			
• clearance		≥ 10 mm	
• creepage		≥ 10 mm	

Technical Information

		PI84	PI85
Coil			
Rated voltage	50/60 Hz AC DC	24-120 V	24V
Must release voltage		AC: $\geq 0,15 U_n$ DC: $0,1 U_n$	
Operating range of supply voltage		see Table 1, 2 and Fig. 4, 5	
Rated power consumption	AC DC	0,75 VA 0,4...0,48 W	

Coil Data - AC 50/60 Hz voltage version

Coil Code	Rated Voltage V AC	Coil Resistance ($\pm 10\%$) at 20 °C	Coil Operating Range V AC	
			min. (at 20 °C)	max. (at 55 °C)
24AC	24	400	19,2	26,4
120AC	120	10 200	96,0	144,0

Coil Data - DC voltage version

Coil Code	Rated Voltage V DC	Coil Resistance ($\pm 10\%$) at 20 °C	Coil Operating Range V DC	
			min. (at 20 °C)	max. (at 55 °C)
24DC	24	1 440	16,8	61,2

PI84 Connection Diagram

(pin side view)

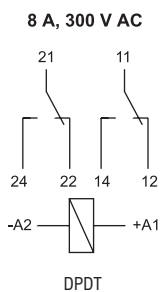

PI85 Connection Diagram

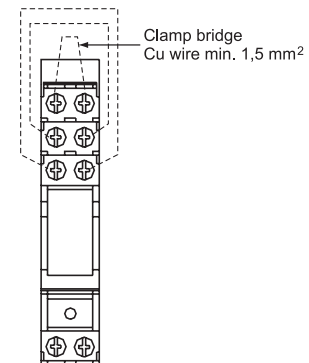
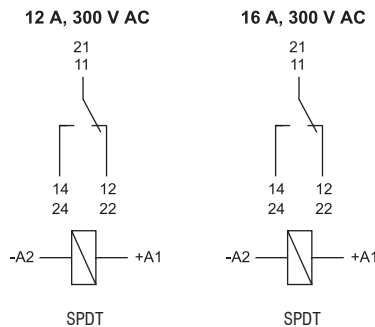
(pin side view)

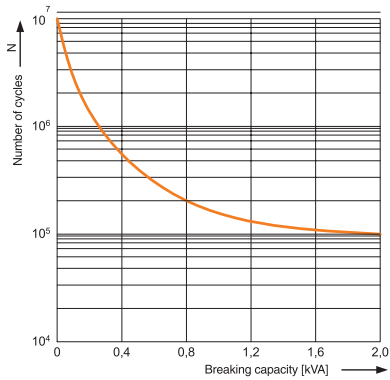

Note: Loads above 12 A require bridging pairs of terminals: 11 with 21, 12 with 22, 14 with 24. Loads up to 12 A do not require bridging of common terminals (such bridges may be fixed, however)

Electrical life at AC resistive load



Electrical life reduction factor at AC inductive load

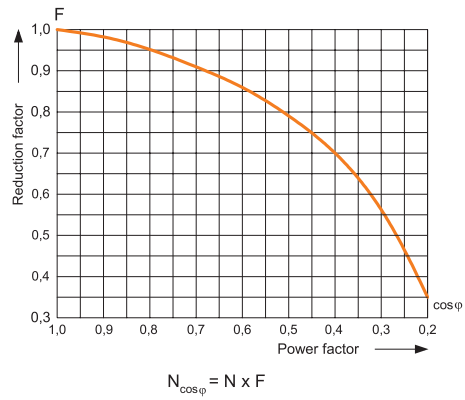

Max. DC resistive load breaking capacity

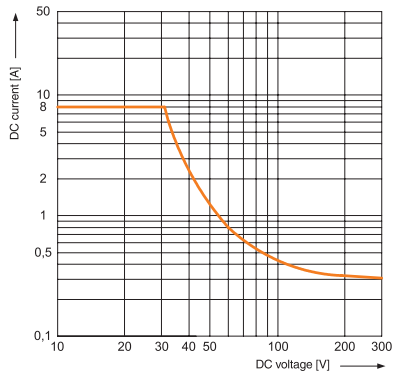

Coil operating range - DC

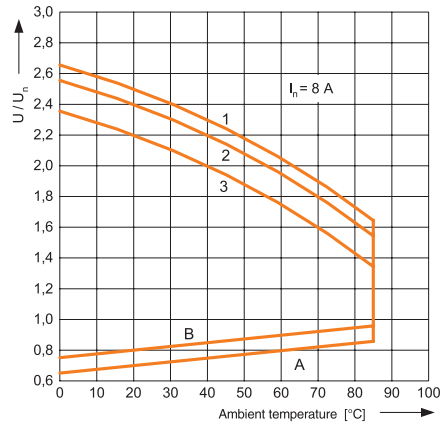

Coil operating range - AC

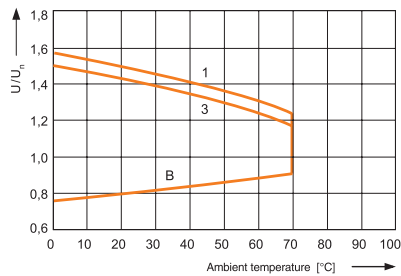

G
Relpol Control Relays

Electrical life at AC resistive load

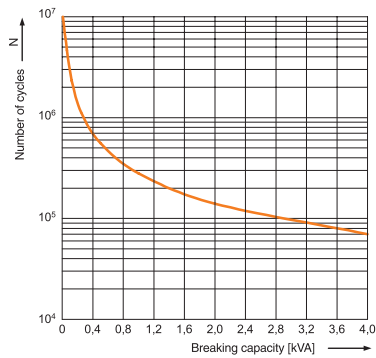

Electrical life reduction factor at AC inductive load

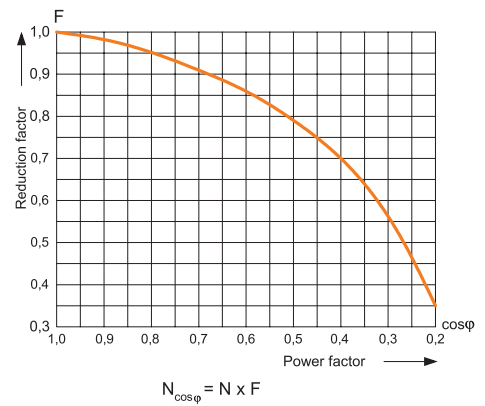

Max. DC resistive load breaking capacity

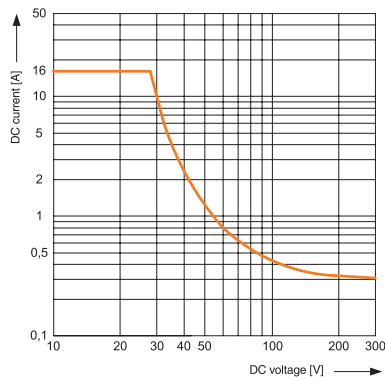

Coil operating range - DC

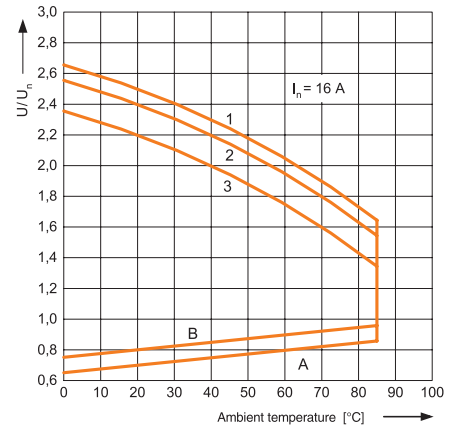

Coil operating range - AC

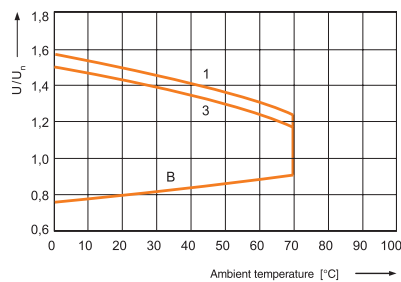

Dimensions are in millimeters (inches). Dimensions not intended for manufacturing purposes.

PI84/PI85 Interface Relay and Socket

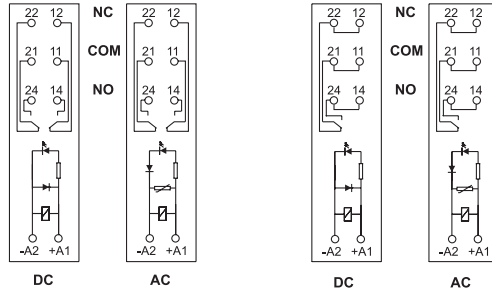
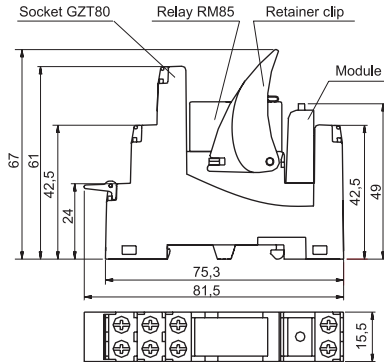

RM84/RM85 Replacement Relay

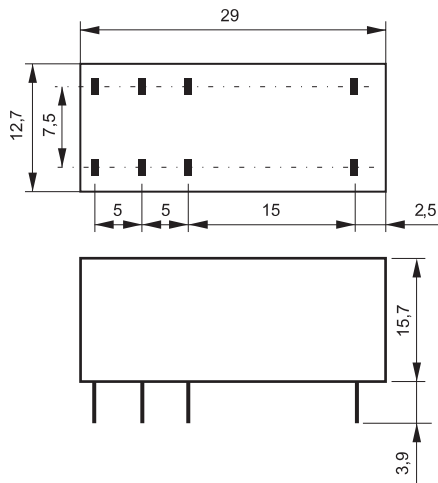

RM84

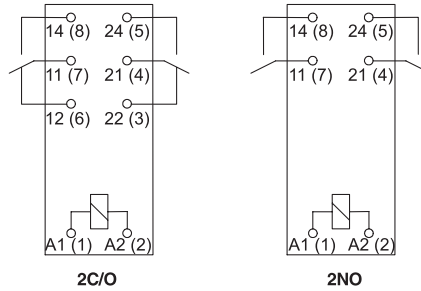

RM85

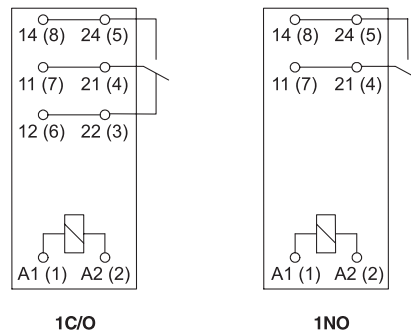

Terminal (pin)	A1(1); A2(2)	22(3); 21(4); 24(5); 12(6); 11(7); 14(8)
mm	φ 0,6	0,5 x 0,9
Drilling hole	for relays φ 1,3 mm ± 0,1 for sockets φ 1,5 mm ± 0,1	

Contacts

Contact number & arrangement	1 C/O	
Contact material	AgSnO₂	
Max. switching voltage	AC/DC	AgSnO ₂ : 250 V / 400 V AC/ 125 V DC
Min. switching voltage	AC/DC	AgSnO ₂ : 10 V
Rated load	AC1	AgSnO ₂ : 6 A / 250 V AC
	DC1	AgSnO ₂ : 6 A / 24 V DC
Min. switching current	AgSnO ₂ : 100 mA / 24 V	
Max. inrush current (20 ms)	AgSnO ₂ : 10 A	
Rated current	6 A	
Max. breaking capacity	AC1	AgSnO ₂ : 1 500 VA
Min. breaking capacity	AgSnO ₂ : 1 W	
Resistance - initially	AgSnO ₂ : ≤ 100mΩ 100 mA, 24 V	
Max. operating frequency		
• at rated load	AC1	360 cycles/hour
• no load		72 000 cycles/hour

Input control circuit

Rated voltage	DC	12-24 V
	AC/DC	24-115 V AC:50/60 Hz
Must release voltage	AC: ≥ 0,2 U _n	
	DC: ≥ 0,1 U _n	
Operating range of supply voltage	see Table 1	
Must operate voltage	AC and DC: ≤ 0,8 U _n	
Rated power consumption	AC/DC	0.3...2.1 VA / 0.3...1.0W
	DC	0.3 W

Insulation

Insulation RATED VOLTAGE	250 V AC (PN-EN 60664-1)	
Rated surge voltage	4 000 V AC 1.2 / 50 μs	
Oversvoltage category	III IEC 61810-52 (PN-IEC 664-1)	
Insulation pollution degree	3	
Dielectric strength		
• input - output	4 000 V AC	50/60 Hz, 1 min., type of insulation: reinforced
• input - output	6 000 V	1,2 / 50 μs, surge voltage
• input - output	2 500 V AC	50/60 Hz 1 min.
• contact clearance	1 000 V AC	50/60 Hz 1 min., type of clearance: micro-disconnection
Input-Output - coil distance		
• clearance	≥ 6 mm	
• creepage	≥ 8 mm	

General data

Operating time (typical value)	AC: 11 ms	DC: 8 ms
Release time (typical value)	AC: 15 ms	DC: 10 ms
Electrical life		
• resistive AC1	360 cycles/hour	> 0,6 x 10 ⁵ 6 A, 250 V AC
• cos φ = 0,4		> 2 x 10 ⁵ 2 A, 250 V AC
Mechanical life (cycles)	> 2 x 10 ⁷	
Dimensions (L x W x H)	98.5 x 6.2 x 85.5 mm	
Weight	45g	
Ambient temperature		
• storage	-40...+70 °C	
• operating	-40...+55 °C	-40...+60 °C 12,24 V DC
Protection category	IP 20, PEN-EN 60529	
Environmental protection	RTI, PEN-EN 116000-3	
Shock resistance	10 g	
Vibration resistance	5 g 10...500 Hz	

① Standard contact materials and coil rated voltages are marked with bold type.

Input Data

Relay code	Nominal input voltage U_n	Input power control circuit (U_p)	Input - voltage range V	
			min.	max.
PIR6W-1P-12VDC	12 V DC	0,3 W	9,6	14,14
PIR6W-1P-24VDC	24 V DC	0,3 W	19,2	28,0
PIR6W-1P-24VAC/DC	24 V AC/DC	0,3 VA / 0,3 W	19,2	26,4
PIR6W-1P-115VAC/DC	115 V DC	0,9 VA / 0,9 W	92,0	130,0

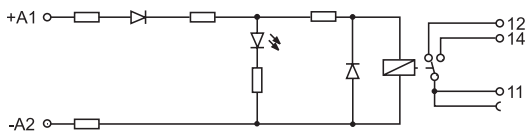
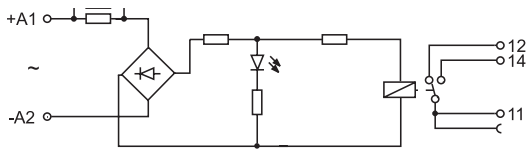
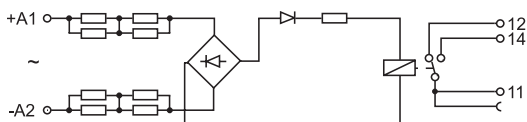
Connection Diagrams
**PIR6W-1P-12VDC
PIR6W-1P-24VDC**

PIR6W-1P-24VAC/DC

PIR6W-1P-115VAC/DC

Mounting

Relays **PIR6W** are designed for 35 mm DIN rail mount, EN 50022.

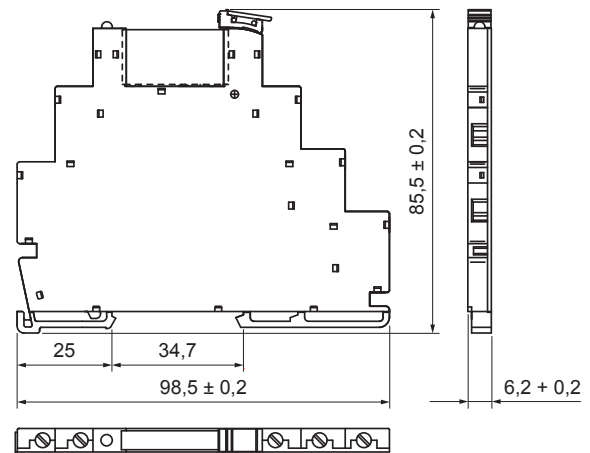
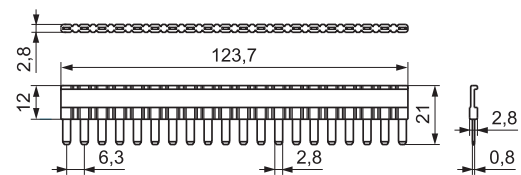
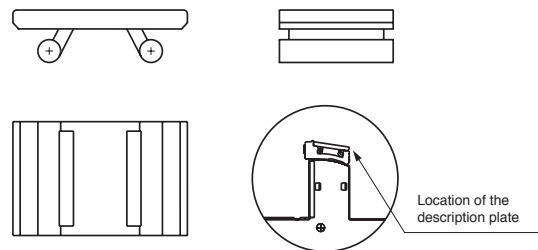
PIR6W are adapted for the co-operation with interconnection strip type **ZG20**. Interconnection strip **ZG20** allows to common bridging outputs or inputs. Maximum current rate is 36 A. Colors of strips: **ZG20-1** red, **ZG20-2** black, **ZG20-3** blue.

Dimensions

Dimensions are in millimeters (inches). Dimensions not intended for manufacturing purposes. ①



Interconnection Strip ZG20

Description Plate PI6W-1246

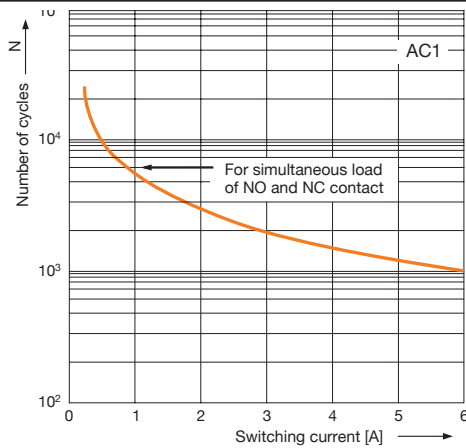
① In March 2016, Relpol changed the DIN-rail fixing place location as represented in this view.

**Electrical life at AC resistive load.
Maximum switching frequency at rated load**

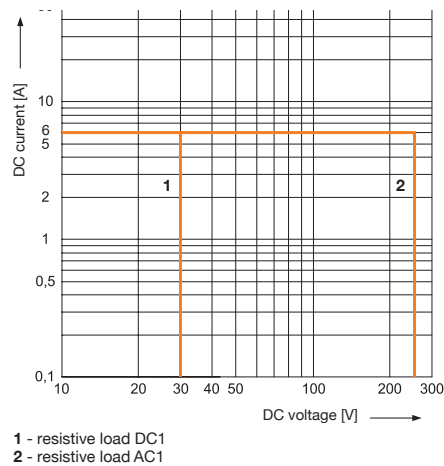

Max. DC resistive load breaking capacity



Coil Operating Range - DC

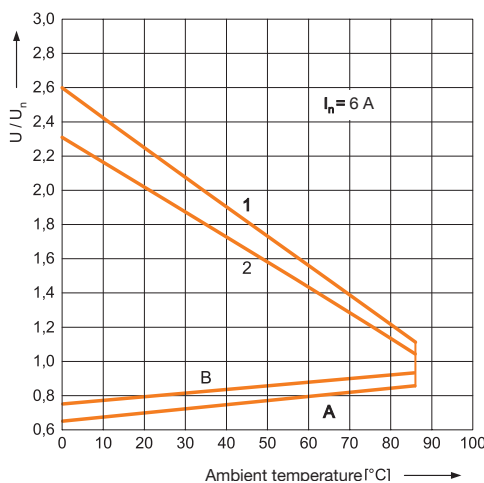

**RM699 Interface Operational Relay
Dimensions**

Dimensions are in millimeters (inches). Dimensions not intended for manufacturing purposes.

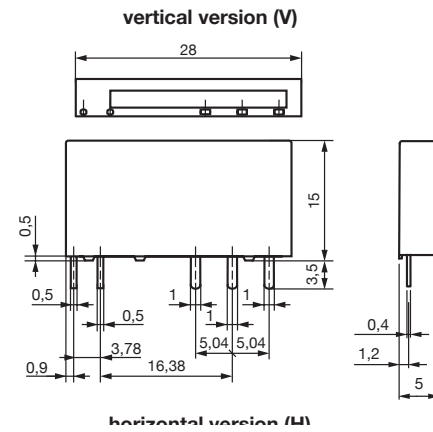

RM699 Connections Diagrams (pin side view)

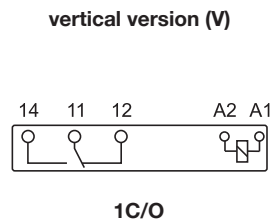

RM699 Mounting openings raster (solder side view)

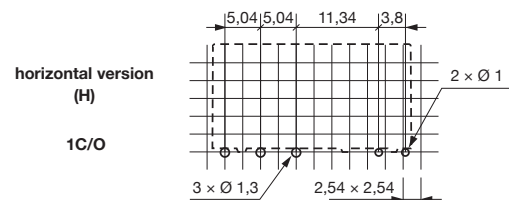

Description of Coil Operating Range

A - relations between make voltage and ambient temperature at no load on contacts. Coil temperature and ambient temperature are equal before coil energizing. Make voltage is not higher than the value read on Y axis (multiplication of rated voltage).

B - relations between make voltage and ambient temperature after initial coil heating up with 1,1 Un, at continues load of In on contacts. Make voltage is not higher than the value read on Y axis (multiplication of rated voltage).

1, 2,3 - values on Y axis represent allowed overvoltage on coil at certain ambient temperature and contact load:

- 1 - no load
- 2 - rated load

GEFRAN

Panel Mount "Hockey Puck" Relays and DIN Rail Mounted Solid State Relays up to 120 Amps



With over forty years of experience, Gefran is the world leader in the design and production of solutions for measuring, controlling, and driving industrial production processes. Gefran's know-how and experience guarantee continuity and tangible solutions. Gefran's line of solid state relays are the ideal solution for applications where high speed switching and long life are essential. In specific applications, solid state relays offer many advantages over electromechanical devices including no moving parts or contact arcing. In addition, solid state relays are directly compatible with logic components such as microprocessors and PLCs.

feature is important in certain medical, residential and industrial applications. The Gefran solid state relays also include built-in metal oxide varistor (MOV) protection to protect against internal damage to the solid state relay.

Output Circuit Features

The Gefran solid state relays feature zero voltage turn-on, which means they are designed to turn on at the next zero crossover after application of the control voltage. This limits electromagnetic interference, reducing the chance of damage to downstream equipment. A built-in MOV reduces the likelihood of damage to the relay from rapid changes in voltage (dv/dt) and transient voltages.

Many safety and convenience features

All Gefran solid state relays come standard with an LED to indicate when the relay is in an operational state. This increases safety and speeds troubleshooting.

In addition, all GQ hockey puck type relays come standard with a load side cover that provides touch protection. The GTS DIN-Rail mounted relays also offer touch protection through the use of a removable protective cover plate.

Broad selection for many applications

The Gefran GQ solid state relays are available in single phase "hockey puck" models up to 90 amps and the GTS DIN-rail single phase units with integral heatsink up to 120 amps. The GTZ three phase models with integral heatsink up to 55 amps are also available.

Opto-isolated input limits current leakage

All Gefran solid state relays feature opto-isolated inputs where an internal LED signals a photosensitive element when output switching is to occur. This provides up to 4,000V isolation between the input voltage and the output voltage and also limits current leakage. This

Common Applications

- Heating controls
- Injection molding machines
- Semiconductor manufacturing equipment
- Glass processing
- Welding controls
- Food processing
- Industrial & commercial ovens
- Soldering machines
- Medical equipment
- Office machinery
- Robotics

Integral heatsink with DIN-rail mounting

A complete selection of solid state relays are available with a built-in heatsink (GTS/GTZ models). This eliminates the hassle of selecting and installing a properly sized heatsink, or mounting to a panel mount relay directly on the back pan with silicone thermoconductive grease.

Approvals

The Series GQ and GTZ solid state relays are cURus approved and CE marked. The GTZ DIN-rail solid state relays are cULus Listed and CE marked.

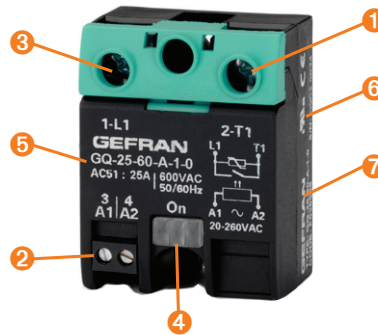

- ❶ Finger Safe Protection Covers
- ❷ AC or DC Input Connections
- ❸ AC Output Connection Models
- ❹ LED Status Indicator
- ❺ Internal MOV protection
- ❻ Integrated or optional heatsinks
- ❼ cURus, CE
- ❽ cULus, CE

Catalog Number Quick Guide

GQ- 15 - 24 - D - 1 - 4

	Nominal Current		Nominal Voltage		Control Voltage		Overtolerance		Connectors	
Hockey Puck	15	15A AC	24	230V AC	D	3...32V DC	1	Internal protection	4	Two-pin screw connector, low profile enclosed
1-Phase	25	25A AC	60	600V AC	A	20...260V AC				
Panel Mount	50	50A AC								
	90	90A AC								

GTS- 25 / 60 - D - 0 -

	Rated Current		Rated Voltage		Control Voltage		Alarm Output		Fan	
1-Phase	15	15A AC	60	600V AC	D	6...32V DC	0	None	VEN-90	230V 14W
DIN Rail mount	25	25A AC				20...260V AC/DC				80x80x40
	40	40A AC							VEN-91	115V 14W
	50	50A AC								80x80x40
	60	60A AC								
	75	75A AC								
	90	90A AC								
	120	120A AC								Required on 120A models only

GTZ 40 / 60 - D - 0 - VEN-91

	Nominal Current		Nominal Voltage		Control Voltage		Alarm Output		Fan	
3-Phase	25	25A AC	60	600V AC	D	6...32V DC	0	None	VEN-90	230V 14W
DIN Rail mount	40	40A AC				20...260V AC/DC				80x80x40
	55	55A AC							VEN-91	115V 14W
										80x80x40
										Required on 40A & 55A models only

Gefran Solid State Relays

1 Pole Panel Mount Relay, 3-32V DC Control, 230V AC Output 



Specifications	15 Amp	25 Amp	50 Amp	90 Amp
	Catalog Number	Catalog Number	Catalog Number	Catalog Number
	GQ-15-24-D-1-4	GQ-25-24-D-1-4	GQ-50-24-D-1-4	GQ-90-24-D-1-4
Input				
Voltage Range	3 - 32V DC	3 - 32V DC	3 - 32V DC	3 - 32V DC
Turn-on Voltage (min.)	≥ 2.7V DC	≥ 2.7V DC	≥ 2.7V DC	≥ 2.7V DC
Turn-off Voltage (max.)	≤ 1V DC	≤ 1V DC	≤ 1V DC	≤ 1V DC
Consumption	≤ 13mA @ 32V	≤ 13mA @ 32V	≤ 13mA @ 32V	≤ 13mA @ 32V
Reverse Voltage	< 36V DC	< 36V DC	< 36V DC	< 36V DC
Output				
Amp Rating AC51	15	25	50	90
Nominal Voltage	24...230V AC	24...230V AC	24...230V AC	24...230V AC
Maximum Voltage	20...253V AC	20...253V AC	20...253V AC	20...253V AC
Zero Switching Voltage	≤ 20V	≤ 20V	≤ 20V	≤ 20V
Frequency Range	45...65 Hz	45...65 Hz	45...65 Hz	45...65 Hz
Dimension (mm)	58 (H) x 45 (W) x 30.5 (D), from base to top of control terminal 45 (D)			

1 Pole Panel Mount Relay, 20-260V AC Control, 230V AC Output 



Specifications	15 Amp	25 Amp	50 Amp	90 Amp
	Catalog Number	Catalog Number	Catalog Number	Catalog Number
	GQ-15-24-A-1-4	GQ-25-24-A-1-4	GQ-50-24-A-1-4	GQ-90-24-A-1-4
Input				
Voltage Range	20...260V AC	20...260V AC	20...260V AC	20...260V AC
Turn-on Voltage (min.)	≥ 15V AC	≥ 15V AC	≥ 15V AC	≥ 15V AC
Turn-off Voltage (max.)	≤ 6V AC	≤ 6V AC	≤ 6V AC	≤ 6V AC
Consumption	≤ 8mA @ 260V AC	≤ 8mA @ 260V AC	≤ 8mA @ 260V AC	≤ 8mA @ 260V AC
Output				
Amp Rating AC51	15	25	50	90
Nominal Voltage	24...230V AC	24...230V AC	24...230V AC	24...230V AC
Maximum Voltage	20...253V AC	20...253V AC	20...253V AC	20...253V AC
Zero Switching Voltage	≤ 20V	≤ 20V	≤ 20V	≤ 20V
Frequency Range	45...65 Hz	45...65 Hz	45...65 Hz	45...65 Hz
Dimension (mm)	58 (H) x 45 (W) x 30.5 (D), from base to top of control terminal 45 (D)			

1 Pole Panel Mount Relay, 3-32V DC Control, 600V AC Output



Specifications	50 Amp	90 Amp
	Catalog Number	Catalog Number
	GQ-50-60-D-1-4	GQ-90-60-D-1-4
Input		
Voltage Range	3 - 32V DC	3 - 32V DC
Turn-on Voltage (min.)	≥ 2.7V DC	≥ 2.7V DC
Turn-off Voltage (max.)	≤ 1V DC	≤ 1V DC
Consumption	≤ 13mA @ 32V	≤ 13mA @ 32V
Reverse Voltage	< 36V DC	< 36V DC
Output		
Amp Rating AC51	50	90
Nominal Voltage	48...600V AC	48...600V AC
Maximum Voltage	40...660V AC	40...660V AC
Zero Switching Voltage	≤ 40V	≤ 40V
Frequency Range	45...65 Hz	45...65 Hz
Dimension (mm)	58 (H) x 45 (W) x 30.5 (D), from base to top of control terminal 45 (D)	





1 Pole Panel Mount Relay, 20-260V AC Control, 600V AC Output







Specifications	50 Amp	90 Amp
	Catalog Number	Catalog Number
	GQ-50-60-A-1-4	GQ-90-60-A-1-4
Input		
Voltage Range	20...260V AC	20...260V AC
Turn-on Voltage (min.)	≥ 15V AC	≥ 15V AC
Turn-off Voltage (max.)	≤ 6V AC	≤ 6V AC
Consumption	≤ 8mA @ 260V AC	≤ 8mA @ 260V AC
Output		
Amp Rating AC51	50	90
Nominal Voltage	48...600V AC	48...600V AC
Maximum Voltage	40...660V AC	40...660V AC
Zero Switching Voltage	≤ 40V	≤ 40V
Frequency Range	45...65 Hz	45...65 Hz
Dimension (mm)	58 (H) x 45 (W) x 30.5 (D), from base to top of control terminal 45 (D)	

DISCONTINUED

1 Pole DIN-Rail Mount Relay, 6-32V DC Control, 600V AC Output



				
Specifications	15 Amp	25 Amp	40 Amp	50 Amp
	Catalog Number	Catalog Number	Catalog Number	Catalog Number
	GTS-15/60-D-0	GTS-25/60-D-0	GTS-40/60-D-0	GTS-50/60-D-0
Input				
Voltage Range	6 - 32V DC	6 - 32V DC	6 - 32V DC	6 - 32V DC
Turn-on Voltage (min.)	> 5.1V DC	> 5.1V DC	> 5.1V DC	> 5.1V DC
Turn-off Voltage (max.)	< 3V DC	< 3V DC	< 3V DC	< 3V DC
Consumption	≤ 10mA @ 32V	≤ 10mA @ 32V	≤ 10mA @ 32V	≤ 10mA @ 32V
Reverse Voltage	< 36V DC	< 36V DC	< 36V DC	< 36V DC
Output				
Amp Rating AC51	15	25	40	50
Nominal Voltage	24...600V AC	24...600V AC	24...600V AC	24...600V AC
Maximum Voltage	20...660V AC	20...660V AC	20...660V AC	20...660V AC
Zero Switching Voltage	< 20V	< 20V	< 20V	< 20V
Frequency Range	50/60 Hz	50/60 Hz	50/60 Hz	50/60 Hz
Dimension (mm)	100 (H) x 24 (W) x 107 (D)	108 (H) x 35 (W) x 142 (D)	108 (H) x 60 (W) x 142 (D)	108 (H) x 60 (W) x 142 (D)

1 Pole DIN-Rail Mount Relay, 20-260V AC Control, 600V AC Output

				
Specifications	15 Amp	25 Amp	40 Amp	50 Amp
	Catalog Number	Catalog Number	Catalog Number	Catalog Number
	GTS-15/60-A-0	GTS-25/60-A-0	GTS-40/60-A-0	GTS-50/60-A-0
Input				
Voltage Range	20...260V AC/DC	20...260V AC/DC	20...260V AC/DC	20...260V AC/DC
Turn-on Voltage (min.)	≥ 15V AC/DC	≥ 15V AC/DC	≥ 15V AC/DC	≥ 15V AC/DC
Turn-off Voltage (max.)	≤ 6V AC/DC	≤ 6V AC/DC	≤ 6V AC/DC	≤ 6V AC/DC
Consumption	≤ 8mA @ 260V AC/DC	≤ 8mA @ 260V AC/DC	≤ 8mA @ 260V AC/DC	≤ 8mA @ 260V AC/DC
Output				
Amp Rating AC51	15	25	40	50
Nominal Voltage	24...600V AC	24...600V AC	24...600V AC	24...600V AC
Maximum Voltage	20...660V AC	20...660V AC	20...660V AC	20...660V AC
Zero Switching Voltage	< 20V	< 20V	< 20V	< 20V
Frequency Range	50/60 Hz	50/60 Hz	50/60 Hz	50/60 Hz
Dimension (mm)	100 (H) x 24 (W) x 107 (D)	108 (H) x 35 (W) x 142 (D)	108 (H) x 60 (W) x 142 (D)	108 (H) x 60 (W) x 142 (D)

DISCONTINUED

1 Pole DIN-Rail Mount Relay, 6-32V DC Control, 600V AC Output

				
Specifications	60 Amp	75 Amp	90 Amp	120 Amp
	Catalog Number	Catalog Number	Catalog Number	Catalog Number
without integrate fan (not required)	GTS-60/60-D-0	GTS-75/60-D-0	GTS-90/60-D-0	
with integrated fan 230V				GTS-120/60-D-0-VEN-90
with integrated fan 115V				GTS-120/60-D-0-VEN-91
Input				
Voltage Range	6 - 32V DC	6 - 32V DC	6 - 32V DC	6 - 32V DC
Turn-on Voltage (min.)	> 5.1V DC	> 5.1V DC	> 5.1V DC	> 5.1V DC
Turn-off Voltage (max.)	< 3V DC	< 3V DC	< 3V DC	< 3V DC
Consumption	≤ 10mA @ 32V	≤ 10mA @ 32V	≤ 10mA @ 32V	≤ 10mA @ 32V
Reverse Voltage	< 36V DC	< 36V DC	< 36V DC	< 36V DC
Output				
Amp Rating @ 40°C	60	75	90	120
Nominal Voltage	24...600V AC	24...600V AC	24...600V AC	24...600V AC
Maximum Voltage	20...660V AC	20...660V AC	20...660V AC	20...660V AC
Zero Switching Voltage	< 20V	< 20V	< 20V	< 20V
Frequency Range	50/60 Hz	50/60 Hz	50/60 Hz	50/60 Hz
Dimension (mm)	108 (H) x 80 (W) x 107 (D)	108 (H) x 127 (W) x 142 (D)	108 (H) x 127 (W) x 142 (D)	108 (H) x 127 (W) x 158 (D)

1 Pole DIN-Rail Mount Relay, 20-260V AC Control, 600V AC Output

				
Specifications	60 Amp	75 Amp	90 Amp	120 Amp
	Catalog Number	Catalog Number	Catalog Number	Catalog Number
without integrate fan (not required)	GTS-60/60-A-0	GTS-75/60-A-0	GTS-90/60-A-0	
with integrated fan 230V				GTS-120/60-A-0-VEN-90
with integrated fan 115V				GTS-120/60-A-0-VEN-91
Input				
Voltage Range	20...260V AC/DC	20...260V AC/DC	20...260V AC/DC	20...260V AC/DC
Turn-on Voltage (min.)	≥ 15V AC/DC	≥ 15V AC/DC	≥ 15V AC/DC	≥ 15V AC/DC
Turn-off Voltage (max.)	≤ 6V AC/DC	≤ 6V AC/DC	≤ 6V AC/DC	≤ 6V AC/DC
Consumption	≤ 8mA @ 260V AC/DC	≤ 8mA @ 260V AC/DC	≤ 8mA @ 260V AC/DC	≤ 8mA @ 260V AC/DC
Output				
Amp Rating @ 40°C	60	75	90	120
Nominal Voltage	24...600V AC	24...600V AC	24...600V AC	24...600V AC
Maximum Voltage	20...660V AC	20...660V AC	20...660V AC	20...660V AC
Zero Switching Voltage	< 20V	< 20V	< 20V	< 20V
Frequency Range	50/60 Hz	50/60 Hz	50/60 Hz	50/60 Hz
Dimension (mm)	108 (H) x 80 (W) x 107 (D)	108 (H) x 127 (W) x 142 (D)	108 (H) x 127 (W) x 142 (D)	108 (H) x 127 (W) x 158 (D)

GTS Relays are cUL (E243386)

3 Pole DIN-Rail Mount Relay, 5-32V DC Control **DISCONTINUED**



Specifications		25 Amp	40 Amp	55 Amp
		Catalog Number	Catalog Number	Catalog Number
Without integrated fan (not required)		GTZ25/60-D-0		
with integrated fan 230V AC			GTZ40/60-D-0-VEN-90	GTZ55/60-D-0-VEN-90
with integrated fan 115V AC			GTZ40/60-D-0-VEN-91	GTZ55/60-D-0-VEN-91
Input	Voltage Range	5 - 32V DC	5 - 32V DC	5 - 32V DC
	Turn-on Voltage (min.)	> 4.5V DC	> 4.5V DC	> 4.5V DC
	Turn-off Voltage (max.)	≤ 3V DC	≤ 3V DC	≤ 3V DC
	Consumption	18 mA @ 5V DC - 22mA @ 32V DC	18 mA @ 5V DC - 22mA @ 32V DC	18 mA @ 5V DC - 22mA @ 32V DC
	Reverse Voltage	< 36V DC	< 36V DC	< 36V DC
Output	Amp Rating AC51	25	40	55
	Nominal Voltage	24...600V AC	24...600V AC	24...600V AC
	Maximum Voltage	24...660V AC	24...660V AC	24...660V AC
	Zero Switching Voltage	< 20V	< 20V	< 20V
	Frequency Range	50/60 Hz	50/60 Hz	50/60 Hz
Dimension (mm)		100 (H) x 24 (W) x 107 (D)	108 (H) x 35 (W) x 142 (D)	108 (H) x 60 (W) x 142 (D)





3 Pole DIN-Rail Mount Relay, 20...260V AC Control, 600V AC Output

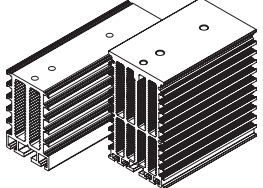
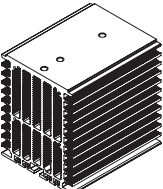
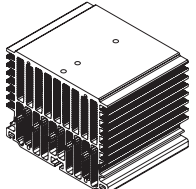

Specifications		25 Amp	40 Amp	55 Amp
		Catalog Number	Catalog Number	Catalog Number
Without integrated fan (not required)		GTZ25/60-A-0		
with integrated fan 230V AC			GTZ40/60-A-0-VEN-90	GTZ55/60-A-0-VEN-90
with integrated fan 115V AC			GTZ40/60-A-0-VEN-91	GTZ55/60-A-0-VEN-91
Input	Voltage Range	20...260V AC/DC	20...260V AC/DC	20...260V AC/DC
	Turn-on Voltage (min.)	≥ 15V AC/DC	≥ 15V AC/DC	≥ 15V AC/DC
	Turn-off Voltage (max.)	≤ 6V AC/DC	≤ 6V AC/DC	≤ 6V AC/DC
	Consumption	≤ 8mA @ 260V AC/DC	≤ 8mA @ 260V AC/DC	≤ 8mA @ 260V AC/DC
Output	Amp Rating @ 40°C	25	40	55
	Nominal Voltage	24...600V AC	24...600V AC	24...600V AC
	Maximum Voltage	24...660V AC	24...660V AC	24...660V AC
	Zero Switching Voltage	< 20V	< 20V	< 20V
	Frequency Range	50/60 Hz	50/60 Hz	50/60 Hz
Dimension (mm)		100 (H) x 24 (W) x 107 (D)	108 (H) x 35 (W) x 142 (D)	108 (H) x 60 (W) x 142 (D)

GTZ Relays are cUR (E243386). Not CSA.

Accessories

Heatsinks	Description	Catalog Number
 <p>DIS-25GD DIS-50G</p>	<p>Heatsink – Extruded aluminum DIN-rail mount for mounting one GQ relay. Includes PAN-1 kit attachment for panel mounting.</p> <ul style="list-style-type: none"> - For use with GQ 15A & 25A relays - 100 x 24 x 65mm - Thermal Resistance $R_{th} > 2.8$ K/W 	DIS-25GD
	<ul style="list-style-type: none"> - For use with GQ 25A & 50A relays - 100 x 60 x 100mm - Thermal Resistance $R_{th} > 8.3$ K/W 	DIS-50G
	<p>Heatsink – Extruded aluminum DIN-rail mount for mounting one GQ relay. Includes PAN-1 kit attachment for panel mounting.</p> <ul style="list-style-type: none"> - For use with GQ 50A relays - 100 x 80 x 100mm - Thermal Resistance $R_{th} > 0.66$ K/W 	DIS-60G
	<p>Heatsink – Extruded aluminum DIN-rail mount for mounting one GQ relay. Includes PAN-1 kit attachment for panel mounting.</p> <ul style="list-style-type: none"> - For use with GQ 90A relays - 100 x 126 x 100mm - Thermal Resistance $R_{th} > 0.56$ K/W 	DIS-90G
	<p>Kit Attachment – Allows for panel mounting the GTS Series and DIS heat sinks. Includes 2 plastic supports, 2 screws, and 2 washers.</p>	PAN-1
	<p>Silicone thermoconductive paste – for coupling the GQ Relay power module to the heat sink. 100 g tube.</p>	SIL-1
	<p>Graphite Film – 35 x 55 mm graphite film for GQ relays.</p> <ul style="list-style-type: none"> - 0.12 mm thick, 2.1 W (m*K). - 200 x 240 mm sheet with 25 adhesives 	SIL-GQ

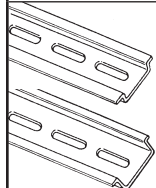
Accessory	Description	Catalog Number
	<p>DIN-rail - 2 meter lengths (6'6") Top Hat, low profile (price per rail) Top Hat, high profile (package of 20, price per rail)</p>	3F 3AF

Cross Reference Series SAR/SAS to Gefran Solid State Relays

Sprecher + Schuh Catalog Number	Gefran Catalog Number	Gefran Product Status
SAR Series DIN-Rail Mount		
SAR6-25-1D	GTS-25/60-D-0	
SAR6-25-1	GTS-25/60-A-0	
SAR6-40-1D	GTS-40/60-D-0	
SAR6-40-1	GTS-40/60-A-0	
SAR6-50-1D	GTS-50/60-D-0	
SAR6-50-1	GTS-50/60-A-0	
SAR6-75-1D	GTS-75/60-D-0	
SAR6-75-1	GTS-75/60-A-0	
SAR6-100-1D	GTS-90/60-D-0	Select GTS-120/60-D... For above 90A+
SAR6-100-1	GTS-90/60-A-0	Select GTS-120/60-A... For above 90A+
~	GTS-120/60-D-0-VEN*	New 120A offering
~	GTS-120/60-A-0-VEN*	New 120A offering
SAR6-30-3D	GTZ25/60-D-0	Select GTZ40/60-D-0-VEN* for above 25A+
SAR6-30-3	GTZ25/60-A-0	Select GTZ40/60-A-0-VEN* for above 25A+
~	GTZ40/60-D-0-VEN*	New 40A offering
~	GTZ40/60-A-0-VEN*	New 40A offering
~	GTZ55/60-D-0-VEN*	New 55A offering
~	GTZ55/60-A-0-VEN*	New 55A offering
SAS Series Panel Mount		
SAS3-10-1D	GQ-15-24-D-1-4	
SAS3-10-1	GQ-15-24-A-1-4	
SAS3-25-1D	GQ-25-24-D-1-4	
SAS3-25-1	GQ-25-24-A-1-4	
SAS3-50-1D	GQ-50-24-D-1-4	
SAS3-50-1	GQ-50-24-A-1-4	
SAS3-75-1D	GQ-90-24-D-1-4	
SAS3-75-1	GQ-90-24-A-1-4	
SAS6-50-1D	GQ-50-60-D-1-4	
SAS6-50-1	GQ-50-60-A-1-4	
SAS6-75-1D	GQ-90-60-D-1-4	
SAS6-75-1	GQ-90-60-A-1-4	

* Suffix code for selected fan voltage

General Application Notes

Heatsinks

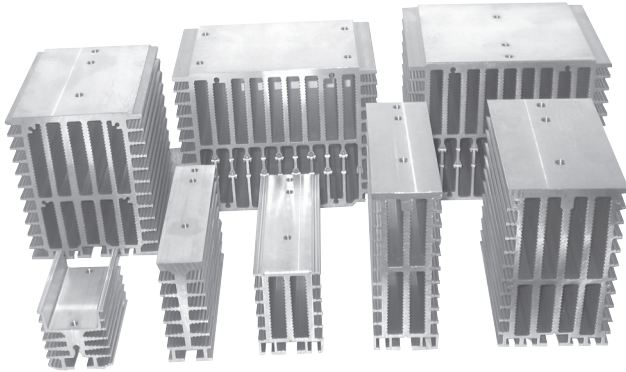

Different models of heatsinks have been designed and tested to meet size and dimension needs.

How to choose a heatsink

- Set max. air temperature inside the panelboard (T_{max_a})
- Set max. operating current: $I_{max} = I_{nom. load} + 10\%$
- Draw on the “graphs” T_{max_a} , I_{max} points.
- Choose the smallest heatsink (starting from upwards), which point [T_{max_a} , I_{max}] is in the gray working area of dissipation curves
- Respect installation distances

Installation

In order to obtain best reliability, it is important to install a heatsink correctly inside the panel, to reach an adequate thermal exchange between the device and the surrounding air in natural convection conditions.

How to install it correctly:

Mount it vertically (max. 10° inclination from the vertical axis)

- Vertical distance between a heatsink and the panel wall: 100 mm at least.
- Horizontal distance between a heatsink and the panel wall: 20 mm at least.
- Vertical distance between two heatsinks: 300 mm at least.
- Horizontal distance between two heatsinks: 40 mm at least.

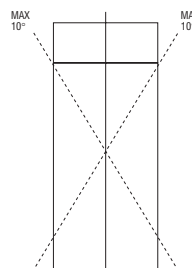

Check that cable channels do not reduce these distances; should it happen, mount the relays overhanging from the panel, so that the air can flow vertically on the heatsink without obstacles (see Fig.1).

Fig. 1

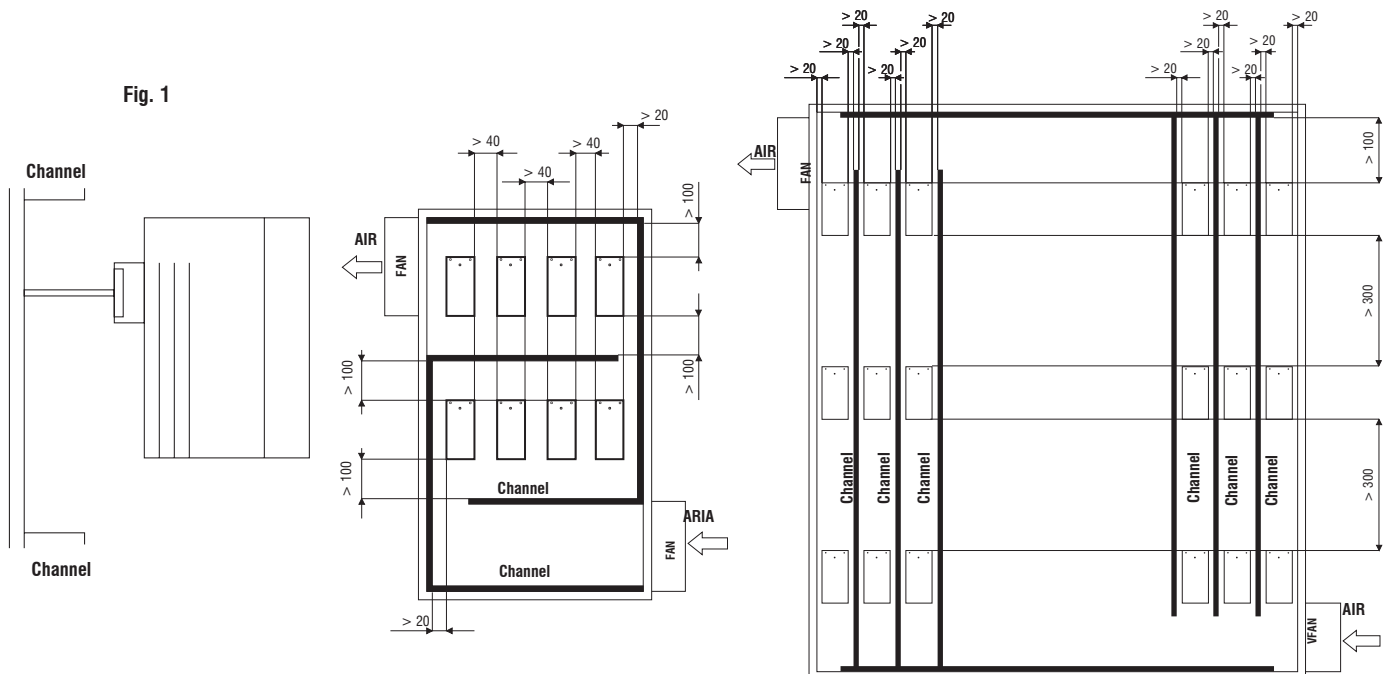

G
Gefran Solid State Relays

General Application Notes *(continued)*

Dissipation Curves

Effective current controllable based on room temperature

G
Gefran Solid State Relays

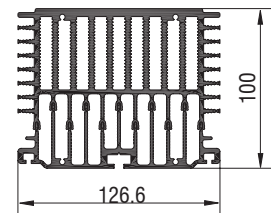
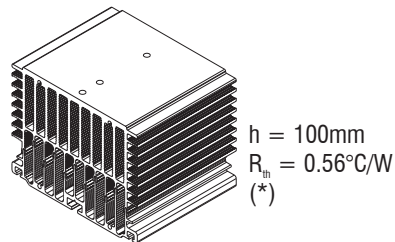
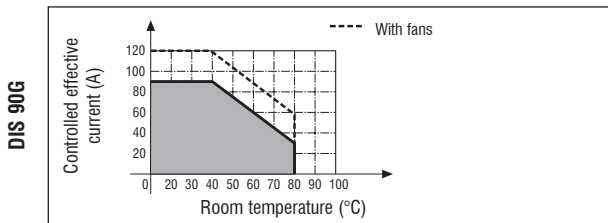
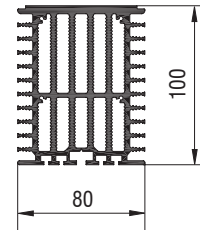
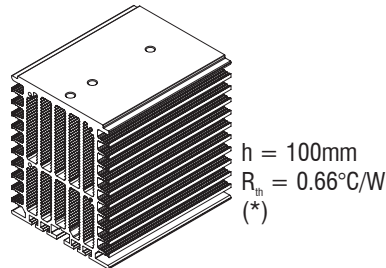
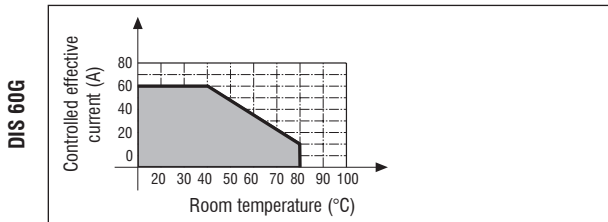
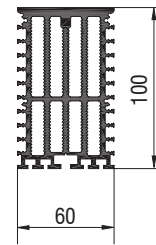
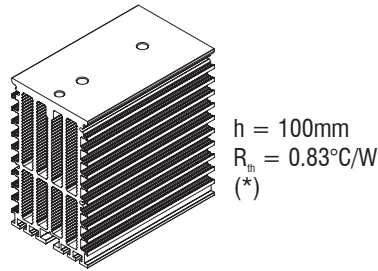
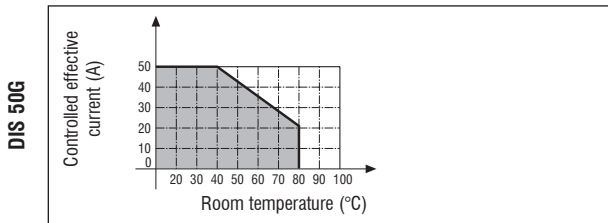
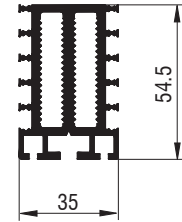
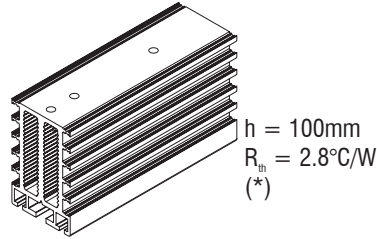
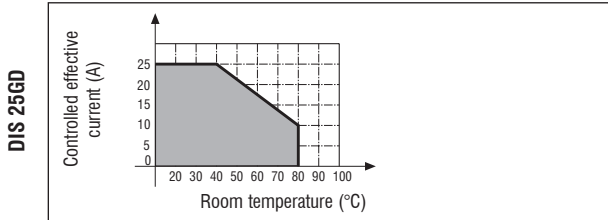

General Application Notes (continued)

Varistors (MOV)

If your application is located near inductive loads, or shares power sources with large inductive loads that are creating transients in excess of the blocking voltage of the Gefran solid state relay, then you must install a metal oxide varistor (MOV) to protect the solid state relay. It is up to the installation company to properly size the MOV to the application! Ideally, the MOV protection is near the noise generating inductive load (such as a motor, drive, or other large inductive coil) or you can place MOVs directly across the output terminals of the SSR.

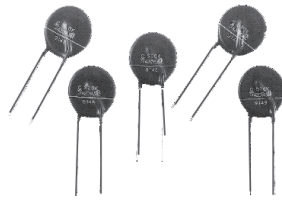

Recommended MOVs from EPCOS:

Part Number	Working Voltage (V)
S20K300	120-290 V AC
S20K420	291-400 V AC
S20K510	401-500 V AC

The Gefran solid state relays include technology that dramatically reduces your need to install an external MOV except in extremely noisy environments or inductive load applications.

Fuses and Fuse Holders

These fuses ensure the maximum safety in solid state relay applications. Fuses with a very high cutoff power are used for this kind of applications. See Table 1.



Table 1.

Recommended Fuses (by others) for GQ, GTS & GTZ Relays					
Type relay	i ² t	Nominal voltage	Size	Dimensions (mm)	Bussman Part No.
GQ 15A	450	230 480	16A	10x38	FWC16A10F
GTS 25A GQ 25A	645 450	230 480 600	25A	10x38	FWC25A10F
GTS 40A	1010	230 480	40A	14x51	FWP40A14
GTS 50A GQ 50A	6600	230 480 600	63A	22x58	FWP63A22F
GTS 60A	6600	230 480 600	80A	22x58	FWP80A22F
GTS 75A	8000	230 480	80A	22x58	FWP80A22F
GTS 90A GQ 90A	11200	230 480 600	100A	22x58	FWP100A22F
GTS 120A	11200	230 480 600	125A	0-0-0-TN/80 100x51x30	170M1418000-TN/80
GTZ 25A	450 645	400 480	25A	12x32	FWC25A10F
GTZ 40A	1010	480 600	40A	14x51	FWP40A14
GTZ 55A	6600	480 600	63A	22x58	FWP63A22F

(*) PF for fuseholders: LEGRAND, PFI for fuseholders: ITALWEBER

G
Gefran Solid State Relays

General Application Notes (continued)

Series GQ Installation notes

- The heat sink must be grounded.
- Power controllers are designed to assure a switching function that does not include protection of the load line or of devices connected to it. The customer must provide all necessary safety and protection devices in conformity to current electrical standards and regulations.
- Protect the solid state relay by using an appropriate heat sink (accessory). The heat sink must be sized according to room temperature and load current.

Dissipated Power Calculation

Single-phase relay

$$Pd \text{ GQ..15/25} = 1.45 * IRMS \text{ [W]}$$

$$Pd \text{ GQ..50/90} = 1.35 * IRMS \text{ [W]}$$

IRMS = single-phase load current

Heatsink Thermal Resistance Calculation

$$R_{th} = (90^{\circ}\text{C} - \text{max amb. T}) / Pd$$

- where Pd = dissipated power
- Max. amb. T = max air temperature inside the electrical cabinet.

Use a heatsink with thermal resistance inferior to the calculated one (Rth).

Maximum surrounding air temperature 40°C suitable for use in pollution degree 2 or better.

Procedure for mounting on heat sink:

The module-heat sink contact surface must have a maximum planarity error of 0.05mm. and maximum roughness of 0.02mm. The fastening holes on the heat sink must be threaded and countersunk.

Attention: spread 1 gram of thermoconductive silicone (we recommend DOW CORNING 340 HeatSink) on the dissipative metal surface of the module. The surfaces must be clean and there must be no impurities in the thermoconductive paste. As alternative it is also possible to use the graphite film SIL-GQ available as accessory.

- Alternately tighten the two fastening screws until reaching a torque of 0.4...0.6 Nm. Wait 5 minutes for any excess paste to drain.
- Alternately tighten the two fastening screws until reaching a torque of 1.2...1.4 Nm.

Installation on heatsink:

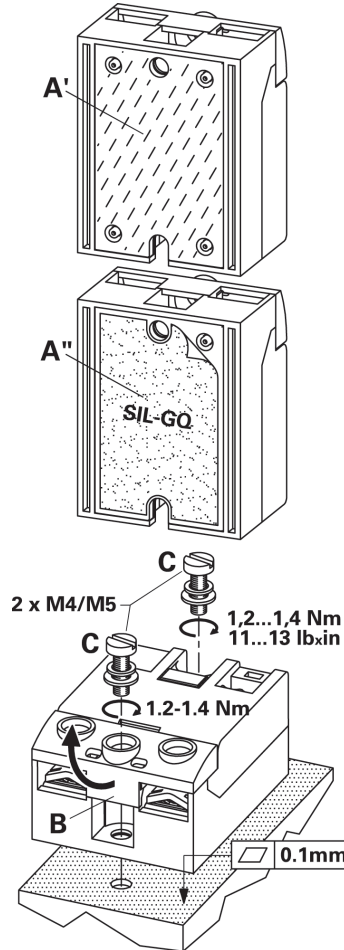

General Application Notes (continued)

Series GTS Installation notes

Power controllers are designed to assure a switching function that does not include protection of the load line or of devices connected to it. The customer must provide all necessary safety and protection devices in conformity to current electrical standards and regulations.

To assure maximum reliability, it is essential to install the unit correctly in the panel in order to guarantee adequate heat exchange between the heat sink and the room under natural convection conditions.

Maximum surrounding air temperature 40°C “Open Type Equipment” suitable for use in pollution degree 2 or better.

Install the unit vertically (max 10° inclination from vertical axis).

- Vertical distance between unit and panel wall >100 mm
- Horizontal distance between unit and panel wall at least 20 mm
- Vertical distance between one unit and the next at least 300 mm
- Horizontal distance between one unit and the next at least 20 mm

Make sure that the wire raceways do not reduce such distances. If they do, install the units cantilevered to the panel so that air can flow vertically onto the heat sink without obstruction.

Equipment should be short circuit protected by semiconductor fuse type:

Model	Fuse manufacturer	Fuse Model size
GTS 15/230	Bussmann Div Cooper (UK) Ltd	FWC16A10F 10x38
GTS 25/60		FWC25A10F 10x38
GTS 40/230, GTS 40/60		FWP40A14F 14x51
GTS 50/230, GTS 50/60		FWP63A22F 22x58
GTS 60/230, GTS 60/60, GTS 75/230, GTS 75/60		FWP80A22F 22x58
GTS 90/230, GTS 90/60		FWP100A22F 22x58
GTS 120/230, GTS 120/60	Bussmann Intn'l Inc. USA	170M1418 000- TN/80

Series GTZ Installation notes

Power controllers are designed to assure a switching function that does not include protection of the load line or of devices connected to it. The customer must provide all necessary safety and protection devices in conformity to current electrical standards and regulations.

To assure maximum reliability, it is essential to install the unit correctly in the panel in order to guarantee adequate heat exchange between the heat sink and the room under natural convection conditions.

Install the unit vertically (max 10° inclination from vertical axis).

- Vertical distance between a heatsink and panel wall >100 mm
- Horizontal distance between a heatsink and panel wall at least 20 mm
- Vertical distance between two heatsink at least 300 mm
- Horizontal distance between two heatsink at least 20 mm

Make sure that the cable raceways do not reduce such distances. If they do, install the GTZ overhanging from the panel, so that the air can flow vertically on the heatsink without obstruction.

Warnings



During continuous operation, the heat sink can reach very high temperatures, and keeps a high temperature even after the unit is turned off due to its high thermic inertia.



DO NOT work on the power section without first cutting out electrical power to the panel.



Follow the instructions in the technical manual.

Technical Information

			GQ-15-24-...	GQ-25-24-...	GQ-50-24-...	GQ-90-24-...	GQ-50-60-...	GQ-90-60-...
Amp Rating	AC51	[A rms]	15	25	50	90	50	90
	AC53	[A rms]	3	5	15	20	15	20
Min. load current		[A rms]	0.1	0.3	0.3	0.5	0.3	0.5
Repetitive overcurrent (t = 1s)		[A rms]	≤ 35	≤ 60	≤ 125	≤ 150	≤ 125	≤ 150
Non-repetitive overcurrent (t = 20 s)		[A p]	200	300	600	1500	600	1500
Current drop at nominal voltage and frequencies		[mA rms]	≤ 8	≤ 8	≤ 8	≤ 10	≤ 8	≤ 10
I ² t for fusing (t = 1-10 ms)		[A ² s]	≤ 200	≤ 450	≤ 1,800	≤ 11,200	≤ 1,800	≤ 11,200
Critical di/dt		[A/μs]	≥ 100	≥ 100	≥ 100	≥ 100	≥ 100	≥ 100
Voltage drop at nominal current		[V rms]	≤ 1.45	≤ 1.45	≤ 1.35	≤ 1.35	≤ 1.35	≤ 1.35
Critical dV/dt off state		[V/μs]	≥ 1000	≥ 1000	≥ 1000	≥ 1000	≥ 1000	≥ 1000
I _{th}		[A]	15	25	50	90	50	90

Input

DC Control

Voltage Range 3 - 32V DC

Turn-on Voltage (min.) ≥ 2.7V DC

Turn-off Voltage (max.) ≤ 1V DC

Consumption ≤ 13mA @ 32V

Reverse Voltage < 36V DC

AC Control

Voltage Range 20...260V AC/V DC

Turn-on Voltage (min.) ≥ 15V AC/V DC

Turn-off Voltage (max.) ≤ 6V AC/V DC

Consumption ≤ 8mA ac/cc @ 260V AC/V DC

Output

Nominal Voltage 24...230V AC 48...600V AC

Maximum Voltage 20...253V AC 40...660V AC

Non-repetitive Voltage 600Vp 1200Vp

Zero Switching Voltage ≤ 20V ≤ 40V

Frequency Range 45...65 Hz 45...65 Hz

Insulation

Nominal voltage input/output [V ac] ≥ 4000

output/case [V ac] ≥ 2500

Resistance input/output [Ω] ≥ 10¹⁰

output/case [Ω] ≥ 10¹⁰

Capacity input/output [pF] ≤ 8

output/case [pF] ≤ 100

Ambient Conditions

Ambient temperature -25...+80°C [-13...176°F]

Storage temperature -55...+100°C [-67...212°F]

Maximum relative humidity 50% at 40°C

Maximum installation altitude 2000 m above sea level

Pollution level 3

Thermal Features

Junction temperature ≤ 125°C [257°F]

R_{th} junction/ambient [K/W] ≤ 12 ≤ 12 ≤ 12 ≤ 12 ≤ 12 ≤ 12

junction/case [K/W] ≤ 1.25 ≤ 1.25 ≤ 0.65 ≤ 0.30 ≤ 0.65 ≤ 0.30

Heatsink R_{th} = (90°C - max amb. T / Pd)

Where Pd = dissipated power

Max. amb. T = max. air temperature inside the electrical cabinet

Use a heatsink with thermal resistance less than the calculated R_{th} value

Terminals and Leads

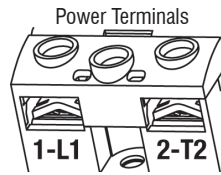

Command Terminals

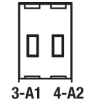

Terminal Type

Screw (m4) contact area (LxP) 13 x 11 mm

screw M2.5 MORS4 (22...16 AWG)

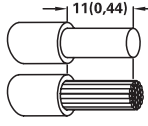
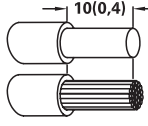
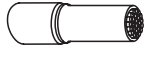
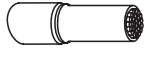
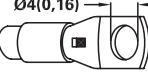
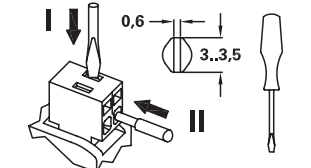
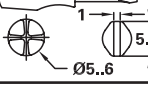
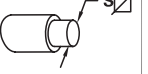
1(L1) 2(T1)		3(A1) 4(A2)		
	1x 2,5...6 mm ² 1x 14...10 AWG 2x 1,5...2,5 mm ² 2x 16...14 AWG 2x 2,5...6 mm ² 2x 14...10 AWG		1x 0,2...2,5 mm ² 1x 24...14 AWG 2x 0,2...1,5 mm ² 2x 24...16 AWG	
	1x 1,5...6 mm ² 1x 16...10 AWG 2x 1,5...6 mm ² 2x 16...10 AWG		1x 0,25...2,5 mm ² 1x 23...14 AWG 2x 0,25...1 mm ² 2x 23...18 AWG	
	1x 2,5...25 mm ² 1x 14...4 AWG			
	2...2,4 Nm 18...21 lbin			
	GQ..15.. 2,5 mm ² 14 AWG	GQ..25.. 6 mm ² 10 AWG	GQ..50.. 12 mm ² (2x6) 7 AWG (2x10)	GQ..90.. 25 mm ² 4 AWG

Recommended Fuses (by others)

HIGH SPEED FUSES			
Model	Size I ² T	Bussman Part No.	Dissipated power @ I _n
GQ15...	16A 150A ² S	FWC16A10F 338470	3,5W
GQ25...	25A 390A ² S	FWC25A10F 338474	6W
	375A ² S	FWC25A14F 338130	7W
GQ50...	50A 1800A ² S	FWC50A14F 338079	9W
	50A 1600A ² S	FWC50A22F 338127	9,5W
GQ90...	80A 6600A ² S	FWP80A22F 338199	14W
	100A 12500A ² S	FWP100A22F 338478	16W

Heatsink / Thermal Resistance

Model	Gefran Heatsink (see accessories)	Thermal Resistance
GQ15... GQ25...	DIS 25GD DIS 50G	$R_{th} \geq 2,8 \text{ K/W}$ $R_{th} \geq 0,83 \text{ K/W}$
GQ50...	DIS 50G	$R_{th} \geq 0,83 \text{ K/W}$
GQ90...	DIS 90G	$R_{th} \geq 0,56 \text{ K/W}$

Data relating to 40°C ambient temperature, heatsink in vertical position with 15 cm of free air above and below.

Section Cable

Model	Section
GQ15...	2.5mm ² / 14 AWG
GQ25...	6mm ² / 10 AWG
GQ50...	12mm ² / 7 AWG
GQ90...	25mm ² / 4 AWG

Minimum allowed rated section based on the rated currents of the power solid state relays, for copper leads isolated in PVC in continuous use and at room temperature of 40°C, according to standards CEI 44-5, CEI 17-11, IEC 408 pursuant to standard EN60204-1.

Power terminals in compliance with standard EN60947-1

EMC Emission

EN 61000-6-4	Emissions conducted at radiofrequency	Class A (Industrial devices)
EN 61000-6-4	Emissions irradiated at radiofrequency	Class A (Industrial devices)

The product is designed for type A environments. Use of the product in type B environments may cause undesired electromagnetic noise. In this case, the user should take appropriate steps for improvement.

EMC Immunity

EN 61000-6-2	Immunity for industrial environments	
EN 61000-4-2	Electrostatic discharges 4kV by contact; 8 kV in air.	Performance criterion 2
EN 61000-4-6	Electromagnetic field at radiofrequency Test level 3. 0.15-80MHz	Performance criterion 1
EN 61000-4-3	Electromagnetic field at radiofrequency Test level 10V/m. 80-1000MHz	Performance criterion 1
EN 61000-4-4	Immunity to burst	Test level 2kV/100 KHz. Performance criterion 2
EN 61000-4-5	Immunity to surge	Test level: 2kV (Phase-ground); 1kV (Phase-phase). Performance criterion 2

Safety

EN 61010-1	Safety requirements
------------	---------------------

Technical Information

Amp Rating		GTS-15	GTS-25	GTS-40	GTS-50	GTS-60	GTS-75	GTS-90	GTS-120
Rated Current @ 40°C (continuous service)	[A rms]	15	25	40	50	60	75	90	120
Non-repetitive overcurrent (t = 20 ms)	[A]	400	400	600	1150	1150	1300	1500	1500
I ² t for blowout	[A ² s]	≤ 450	≤ 645	≤ 1010	≤ 6600	≤ 6600	≤ 8000	≤ 11,200	≤ 11,200
dV/dt critical with output deactivated	[V/μs]	1000	1000	1000	1000	1000	1000	1000	1000

Input		
DC Control	Voltage Range	6 - 32V DC
	Turn-on Voltage (min.)	> 5.1V DC
	Turn-off Voltage (max.)	< 3V DC
	Consumption	≤ 10mA @ 32V
	Reverse Voltage	< 36V DC
AC Control	Voltage Range	20...260V AC/DC
	Turn-on Voltage (min.)	≥ 15V AC/DC
	Turn-off Voltage (max.)	≤ 6V AC/DC
	Consumption	≤ 8mA @ 260V AC/DC

Output		
	Nominal Voltage	24...600V AC
	Maximum Voltage	20...660V AC
	Non-repetitive Voltage	500Vp for 230V models, 1200Vp for 480V models
	Zero Switching Voltage	< 20V
	Frequency Range	50/60 Hz

Isolation		
Rated voltage	input/output	[V ac] ≥ 4000

Ambient Conditions		
Ambient temperature		0°...+80°C [32°...+176°F] according to dissipation curves
Storage temperature		-20...+85°C [-4°...+185°F]
Maximum relative humidity		50% at 40°C
Maximum installation altitude		2000m above sea level
Pollution level		3

Dissipation Curves

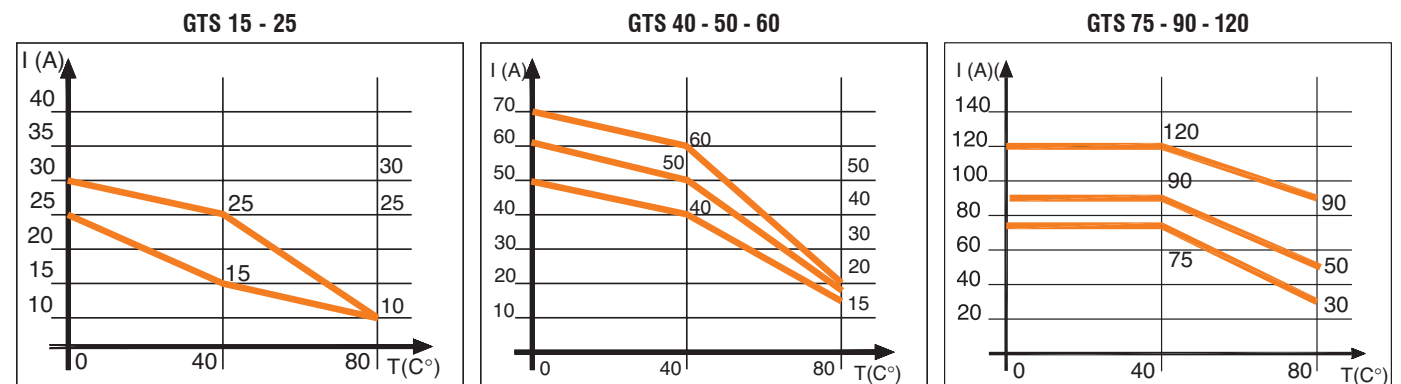

N.B.: Curves for the GTS 120 refer to the device complete with standard running.

Technical Information

Terminal and Conductors

Size	Terminal	Contact area (WxD) screw type	Type of preisolated terminal ②	Max section. ① conductor tightening torque
15/20A	C	6.4x9 M3	1, 2, 4	6mm ² / 10AWG 0.6Nm max
	P	6.4x9 M3	1, 2, 4	6mm ² / 10AWG 0.4 - 0.6Nm
	G	9x12 M5	1	6mm ² / 10AWG 1.3 - 1.8Nm
25A	C	6.4x9 M3	1, 2, 4	6mm ² / 10AWG 0.6Nm max
	P	6.4x9 M3	1, 2	6mm ² / 10AWG 0.4 - 0.6Nm
	G	9x12 M5	1	6mm ² / 10AWG 1.3 - 1.8Nm
40A	C	6.3x9 M3	1, 2, 3	2.5mm ² / 14AWG 0.6Nm max
	P	12x12 M5	1, 2	16mm ² / 6AWG 1.5 - 2.2Nm
	G	11.5x12 M5	1	16mm ² / 6AWG 1.5 - 2.2Nm
50/60A	C	6.3x9 M3	1, 2, 3	2.5mm ² / 14AWG 0.6Nm max
	P	16x18 M6	1, 2	50mm ² / 0AWG 3.5 - 6Nm
	G	14x16 M5	1	50mm ² / 0AWG 1.8 - 2.5Nm
75-90A	C	6.3x9 M3	1, 2, 3	2.5mm ² / 14AWG 0.6Nm max
	P	16x18 M6	1, 2	50mm ² / 0AWG 3.5 - 6Nm
	G	14x16 M5	1	50mm ² / 0AWG 1.8 - 2.5Nm
120A	C	6.3x9 M3	1, 2, 3	2.5mm ² / 14AWG 0.6Nm max
	P	16x18 M6	1, 2	50mm ² / 0AWG 3.5 - 6Nm
	G	14x16 M5	1	50mm ² / 0AWG 1.8 - 2.5Nm

Terminal: C = Control, P = Power, G = Ground

Terminal Types



1. Eyelet



2. Fork



3. Tip



4. Faston

① The max. sections specified refer to unipolar copper wires isolated in PVC..

② The screw terminals must be suitable for field wiring connection only when the wire is provided with eyelet tube terminal type 1.

Technical Information

Amp Rating		GTZ-25/60	GTZ-40/60	GTZ-55/60	GTZ-40/60	GTZ-55/60
Category AC51, AC53a	[A rms]	25	40	55	40	55
Nominal current (I _{max})	[A rms]	3x25	3x40	3x55	3x40	3x55
Non-repetitive overcurrent (t = 20 ms)	[A]	400	600	1150	600	1150
I ² t for blowout	[A ² s]	645	1010	6600	1010	6600
DC Control Input	Voltage Command Circuit (U _c)	5...32V DC				
	Turn-on Voltage (min.)	> 4.5V DC				
	Turn-off Voltage (max.)	< 3V DC				
	Consumption	≤ 18mA @ 5V DC - 22mA @ 32V DC				
	Reverse Voltage	< 36V DC				
AC Control INPUT	Voltage Range	20...260V AC/DC				
	Turn-on Voltage (min.)	≥ 15V AC/DC				
	Turn-off Voltage (max.)	≤ 6V AC/DC				
	Consumption	≤ 8mA @ 260V AC/DC				
	Frequency Range	50/60 Hz				
Activation Time	≤ 1/2 cycle					
Deactivation Time	≤ 1/2 cycle					
Critical dV/dt OFF-state	[V/μs]	1000				
Potential drop at rated current	[Vrms]	≤ 1.4				
Peak Voltage	> 1200V DC					
Protection	IP20					
Isolation						
Nominal voltage (U _i)	[V ac]	600				
Insulation						
Nominal voltage input/output	[KV ac]	4				
Nominal impulse withstand (U _{imp})	[V AC]	2500				
Ambient Conditions						
Working temperature	-20...+80°C [-4°...176°F]					
Storage temperature	-20...+85°C [-4°...185°F]					
Maximum relative humidity	50% at 40°C					
Maximum installation altitude	1000m asl					
Pollution level	3 (suitable for use in degree 2 environment)					
Class	A (industrial device)					

Dissipation Curve

GTZ 25 - 40 - 55

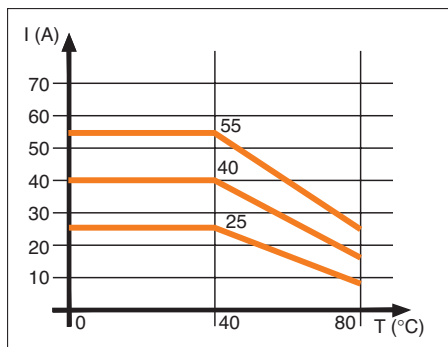

Technical Information

Terminals and Conductors

Size	Nominal Section Cable mm ²	Control Terminal (A1, A2, B1, B2)			Power Terminal (L1, L2, L3, T1, T2, T3)			Ground Terminal ①	
		Contact area (WxD) screw type	Type of preisolated terminal	Section conductor tightening torque ②	Contact area (WxD) screw type	Type of preisolated terminal	Max. section conductor tightening torque	Contact area (WxD) screw type	Max. section conductor tightening torque
25A	6	6,3x9 M3	Eye / fork / tip	min. 0.35 mm ² max. 2.5 mm ² 0.6 Nm Max	12 x 12 M5	Eye / fork / tip	<i>Tip Terminal</i> min. 1mm ² (17AWG) max. 10mm ² (7AWG) <i>Eye or Fork Terminal</i> min. 1mm ² (17AWG) max. 16mm ² (5AWG) 1.5 ... 2.2Nm	12x12 self-tapping screw 3.9x12 DIN7981	min. 1mm ² (17AWG) max. 16mm ² (5AWG) 1.5 ... 1.8Nm
40A	10								
55A	16							12x12 M5	min. 1mm ² (17AWG) max. 16mm ² (5AWG) 2.5Nm

① Note: The maximum sections specified refer to unipolar copper wires isolated in PVC. For the ground terminal, an eye wire terminal is required.
(WxD) = Width x depth

② The minimum acceptable nominal section based on the nominal currents of the power solid state units is given for copper conductors isolated in PVC, under continuous operating conditions and at 40°C ambient temperature according to standards CEI 44-5, CEI 17-11, IEC 408 in accordance with EN60204-1.

G
Gefran Solid State Relays

Connection Examples

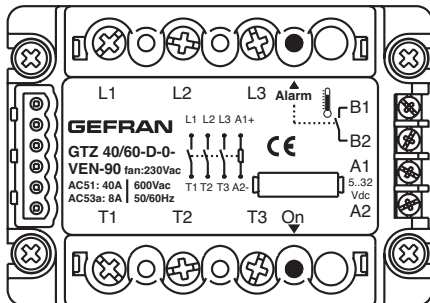

- L1 : Phase 1 input
- L2 : Phase 2 input
- L3 : Phase 3 input
- T1 : Phase 1 output
- T2 : Phase 2 output
- T3 : Phase 3 output
- A1 : Control signal (+)
- A2 : Control signal (-)
- B1 : Alarm output (+) (Special unit)
- B2 : Alarm output (-) (Special unit)
- Led1: Red led signal indicator
- Led2: Yellow led (alarm overtemperature junction)

Series GQ Solid State Relays

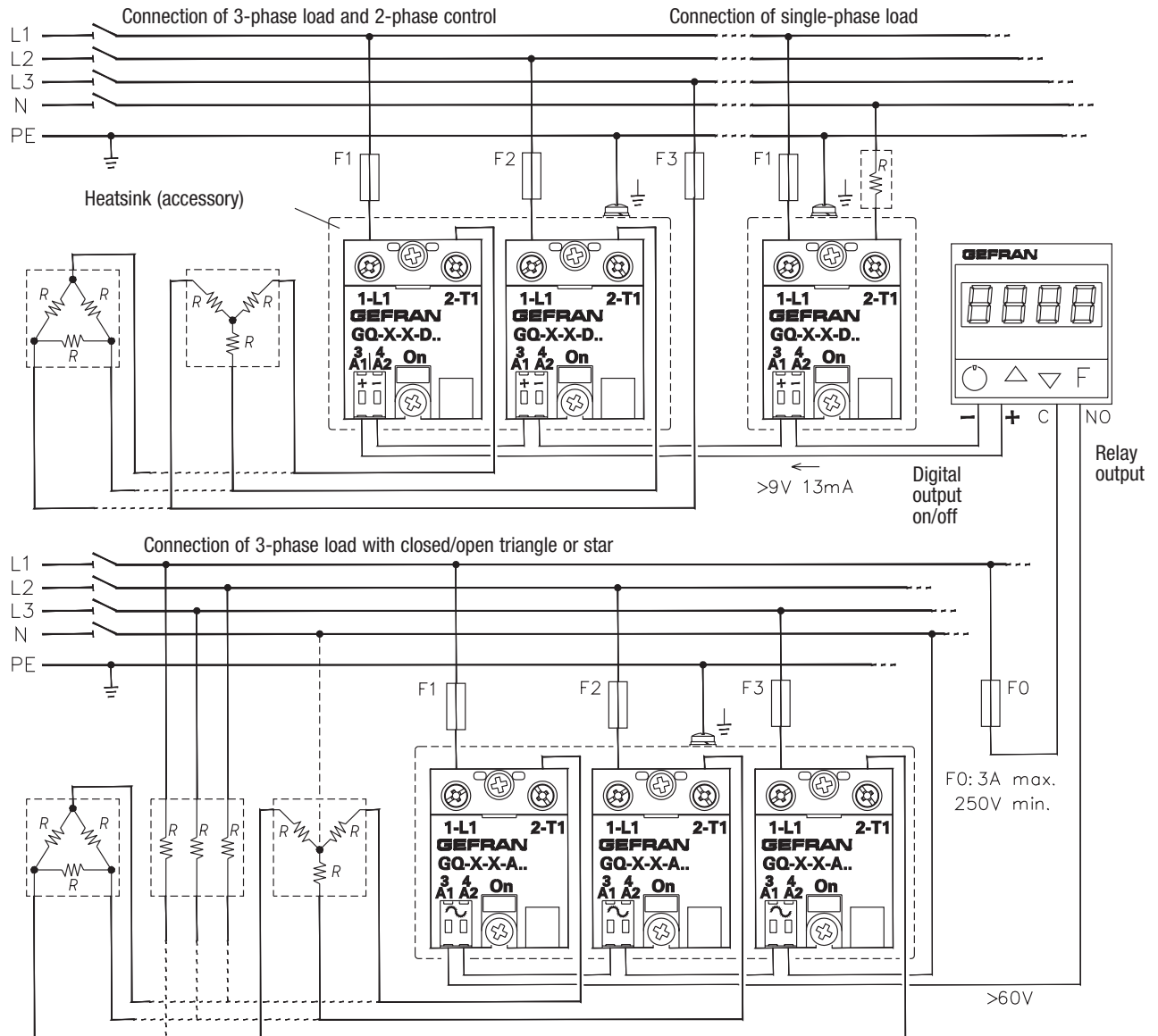

Series GQ Fuse Connections

The solid state group must be connected using proper fuses against short circuits

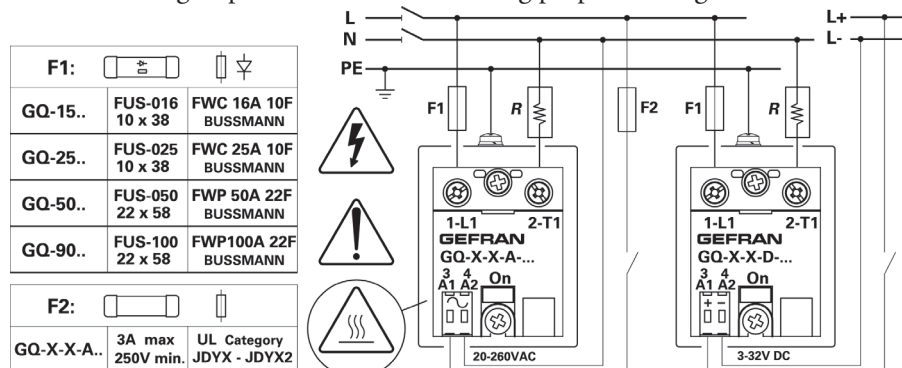

Series GTS Solid State Relays

Single-phase connection

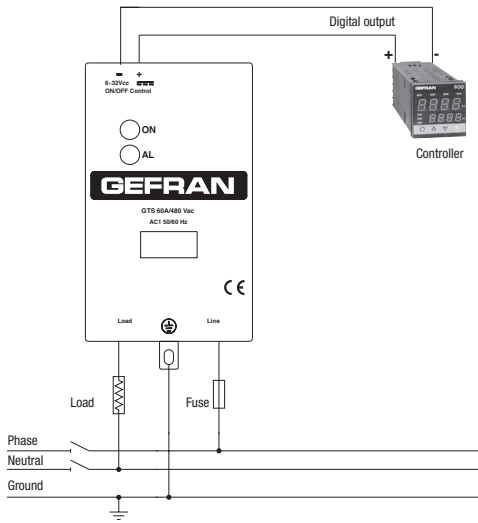

Three-phase Star connection with neutral

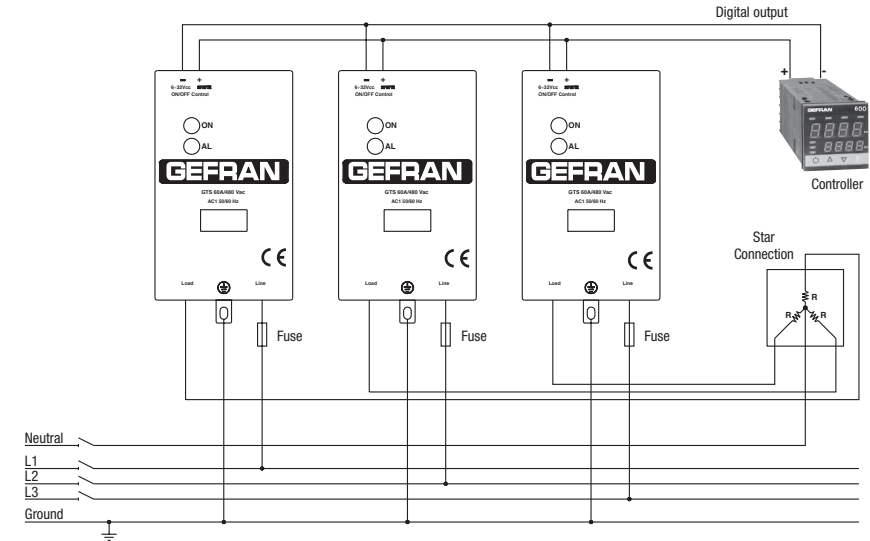

Three-phase Triangle or Star connection without neutral on two phases

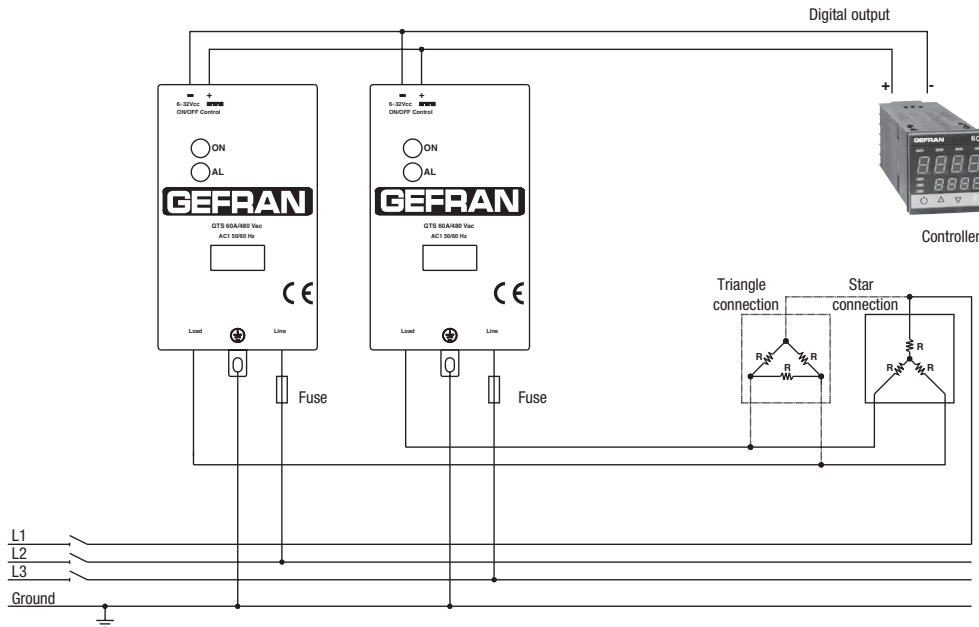

Series GTZ Solid State Relays

Three-phase Triangle or Star connection (with and without neutral)

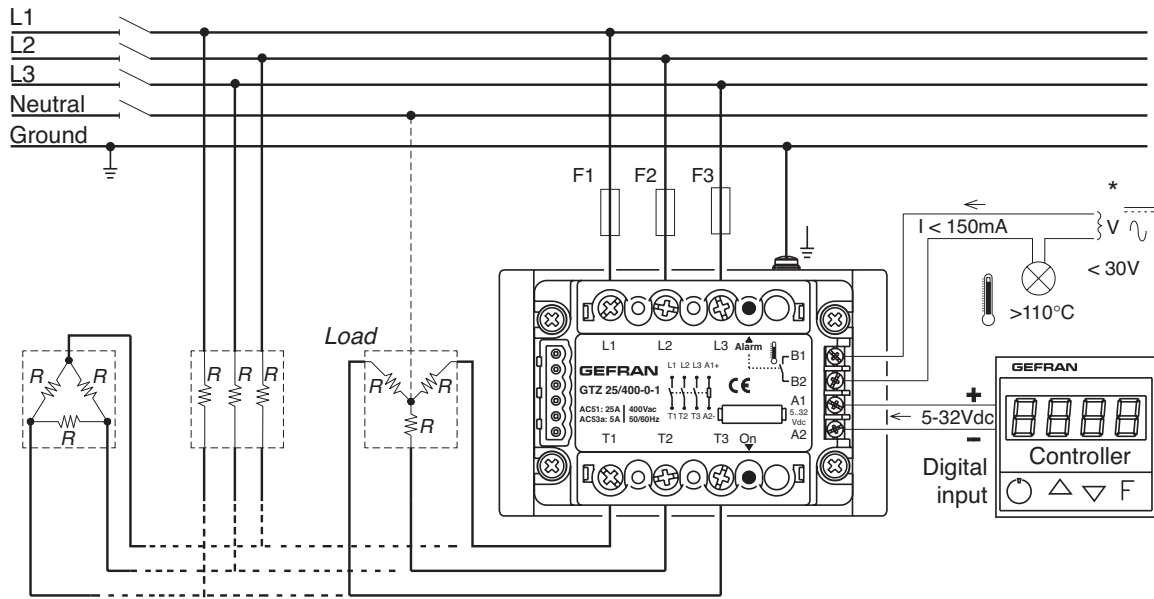

* Only in the version with option overtemperature alarm output

GQ Panel Mount Relays

Dimensions are in millimeters (inches). Dimensions not intended for manufacturing purposes.

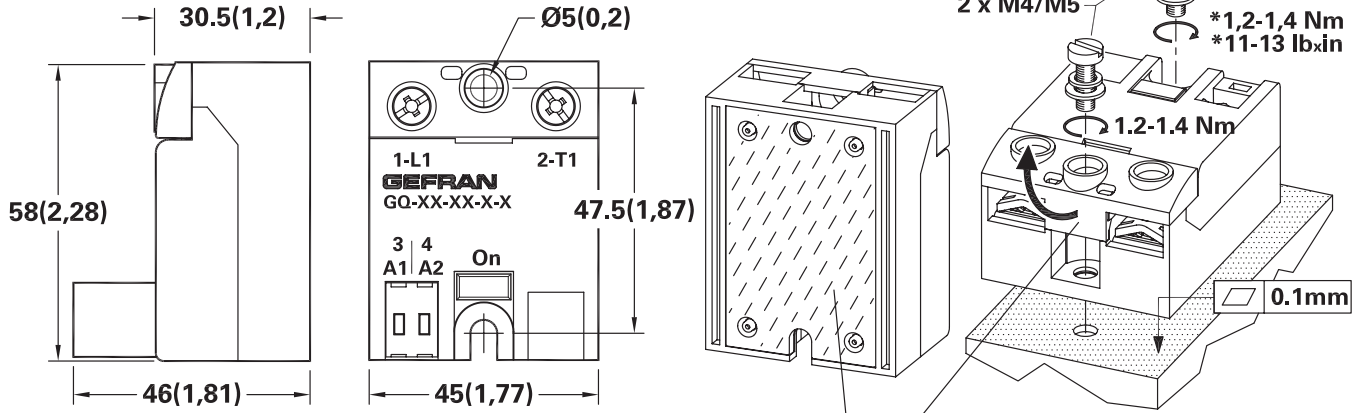

(*) See installation notes

*Apply thermoconductive paste

Raise the guard to access the fastening hole or the terminals

GTS 1-Pole DIN-Rail Mount Relays

Dimensions are in millimeters (inches). Dimensions not intended for manufacturing purposes.

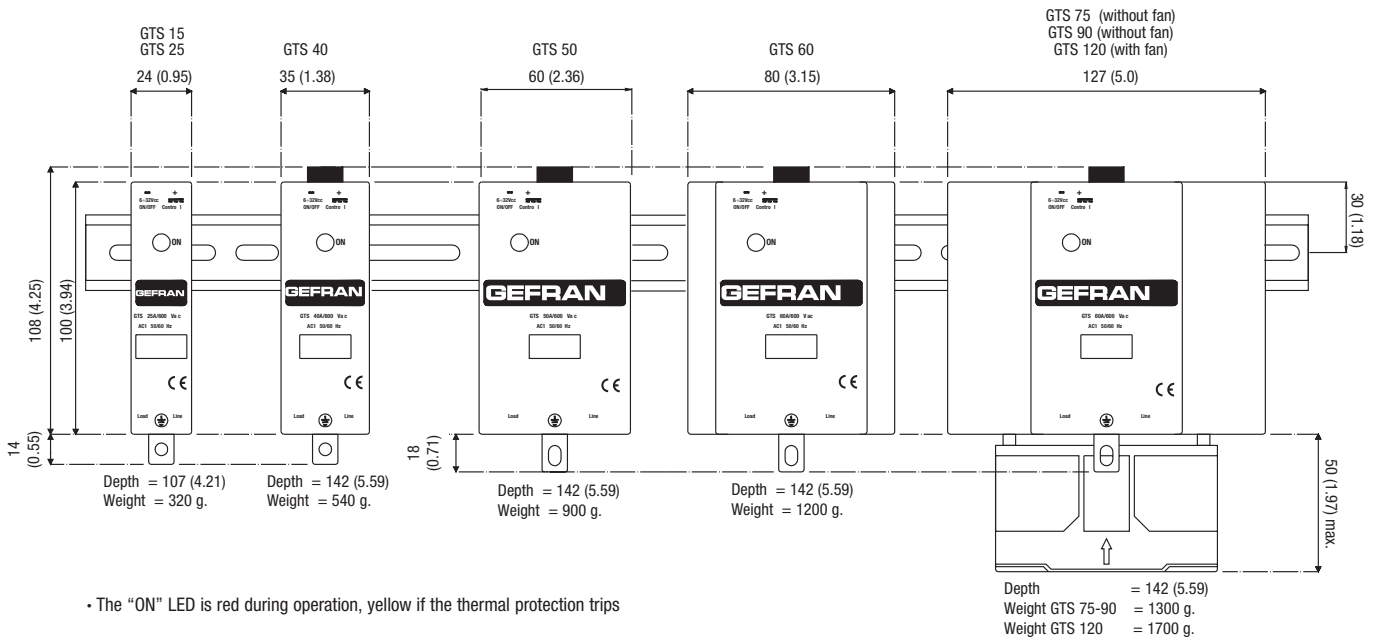

PAN-1 Panel Mount Accessory for GTS - Hole Template

GTS 1-Pole Relays	Length	Width
	mm (inches)	mm (inches)
GTS-15...25	112 (4.41)	0 (0.00)
GTS-40	112 (4.41)	25 (0.98)
GTS-50...60	112 (4.41)	44 (1.73)
GTS-90...120	112 (4.41)	113 (4.45)

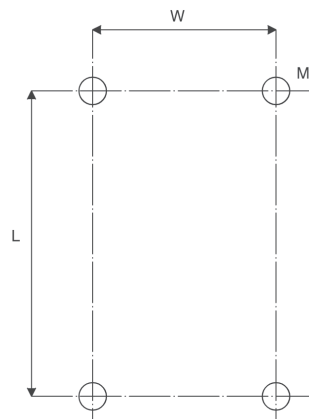

G
Gefran Solid State Relays

GTZ 3-Pole DIN-Rail Mount Relays

