

TIMER TR:  
 ICTO - INSTANTANEDUS CLOSE  
 TIME TO OPEN  
 TC - TIME CLOSE

PDB (WHEN REQUIRED)

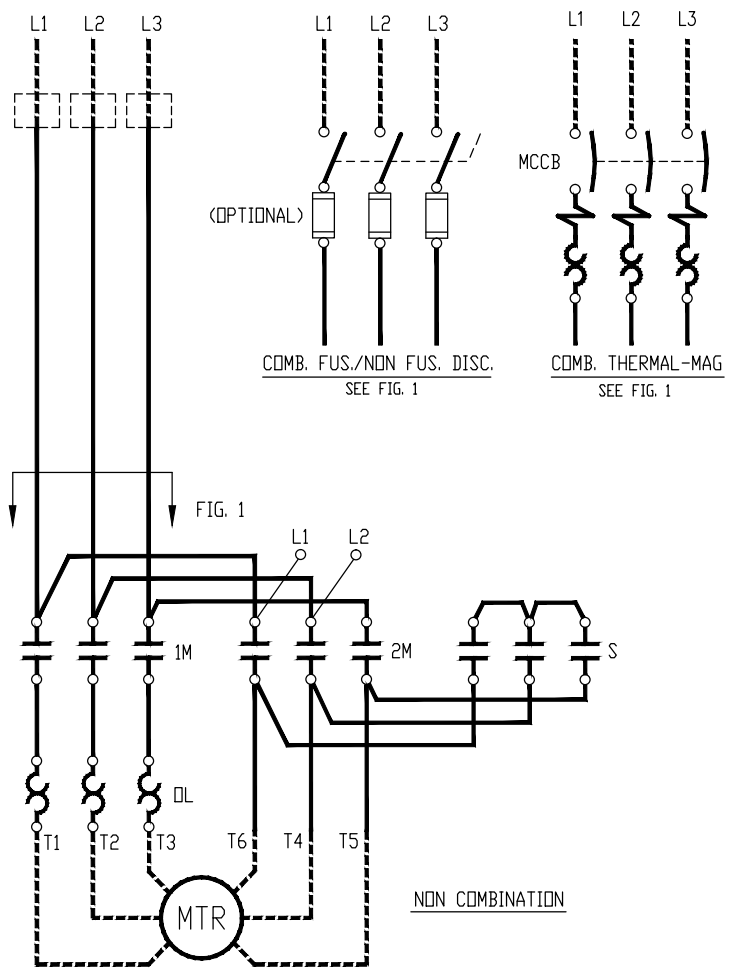

NON COMBINATION

NOTES:

- 1). OVERLOAD RELAY SETTING: MOTOR FLC X 0.58.
- 2). X2 TERMINAL GROUNDED AS STANDARD, REMOVE IF NOT REQUIRED.
- 3). MI STANDS FOR MECHANICAL INTERLOCK.
- 4). TIMING RELAY TR: RZ7-FSY2 WYE DELTA TIMER.
- 5). TERMINAL NUMBERS IN ( ) ARE USED FOR ALTERNATIVE AUX. NUMBERS.

9	GENERAL REVISION.	4-24-12	MR
REV	DESCRIPTION	DATE	APP'D
DESIGNED EAP	REDUCED VOLTAGE STARTER WYE DELTA - THREE CONTACTOR OPEN TRANSITION LOCAL START-STOP PUSHBUTTON	<b>sprecher+schuh</b> HOUSTON, TEXAS DWG. NO. CAYT WS-107-21      SERIES 100	
DRAWN EAP			
APPROVED PAB			
DATE 10-17-90			